

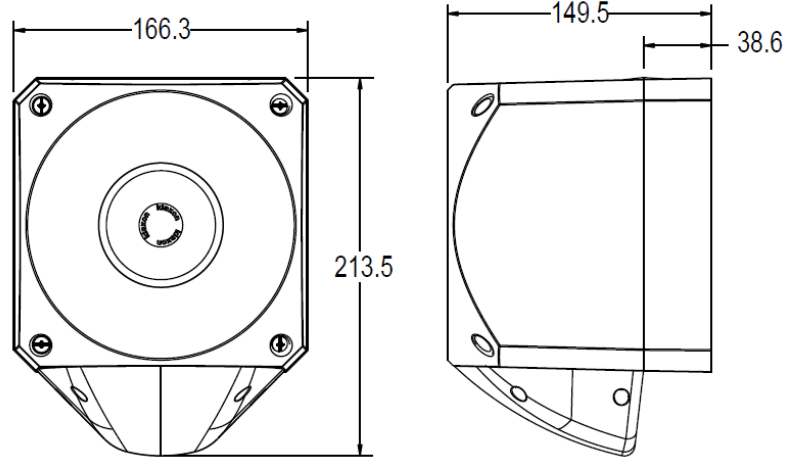

- Sound Output: 120dB(A)
- Light Output: 5J (Xenon)
- 64 Tone, 3 Stages
- IP Rating: 66
- Lens Colour: Amber Blue Clear Green Red
- Available Voltages: 24Vdc
110Vac 230Vac
- LED version can have flashing or static beacon

Max sound output	120dB
Nominal sound output	120dB
Alarm tones	64
Alarm stages	3
Light source	Xenon beacon LED beacon (DC only)
Light output	5J (Xenon beacon)
IP rating	66
Volume control	20dB
Cable entry	M20 knockouts
Operating temp.	-25°C to +55°C (AC) -25°C to +70°C (DC)
Unit material	ABS
Body colour	Red
Lens material	Polycarbonate
Lens colour	Amber, Blue, Clear, Green, Red
Unit weight	2.0 Kg



Beacon type	Voltage options	Voltage tolerance	Current
Xenon	24 Vdc	10 to 60 Vdc	450 to 880mA
Xenon	110/230 Vac	+/- 10%	270mA
LED (flashing)	24 Vdc	10 to 60 Vdc	138 to 568mA
LED (static)	24 Vdc	10 to 60 Vdc	185 to 615mA

Approvals:

(specify required approval when ordering)

EN54-3 compliant.

EMC certified.

CPD certified. DC version only

VdS certified. DC version only

NF certified. DC version only