

# LGM

## PRODUCTS

+44 1252 725257  
sales@lgmproducts.com

# LRS 04 Ex

## Ex duct detector



Response type: Optical

IP rating: IP54

Airflow: 1-20m/s

Suitable for use in zones: 1, 2

Fire  
detection



Hazardous  
area



Tel: +44(0)1252 725257

Fax: +44(0)1252 727627

© 2018/19 LGM Products Ltd.

Email: sales@lgmproducts.com

Web: www.lgmproducts.com

ISO 9001:2015 certified

Address: LGM Products Ltd, Unit 15 Riverside Industrial Park, Farnham, Surrey, GU9 7UG, United Kingdom.

# LGM

## PRODUCTS

+44 1252 725257  
sales@lgmproducts.com

# LRS 04 Ex

## Ex duct detector

<b>Response type</b>	Optical
<b>Airstream</b>	1—20 m/s
<b>IP rating</b>	IP54
<b>Supply voltage</b>	20—28Vdc
<b>Current (with 28Vdc)</b>	Quiescent: Max. 12mA Alarm: Max. 1.8A Failure: Max 2.7mA
<b>Relay contact</b>	Max switching voltage: 30Vdc/30Vac Max switching current: 1A Switching power: Max. 2.7mA
<b>Indication</b>	Contamination and fault indication
<b>Cable entry</b>	2 ATEX glands M16 x 1.5 1 'mushroom' plug
<b>Unit weight</b>	2.74kg (including inlet tube)
<b>Operating temp.</b>	-20°C to +70°C
<b>Body material</b>	Polycarbonate, polyester and aluminium
<b>Unit colour</b>	Blue (with black white and transparent elements)
<b>Approvals</b>	ATEX (IBExU04ATEX1105, IBExU04ATEX1106 )

### Available accessories include:

NAG 03 - Power Supply and Tripping unit  
SAB 04 - Signal and Display Control Element  
422 Ex - Manual Activation Pushbutton  
RZA 142 - Smoke Switch Condition Indicator

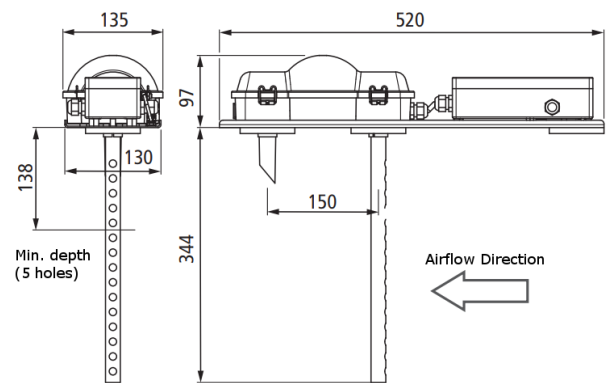
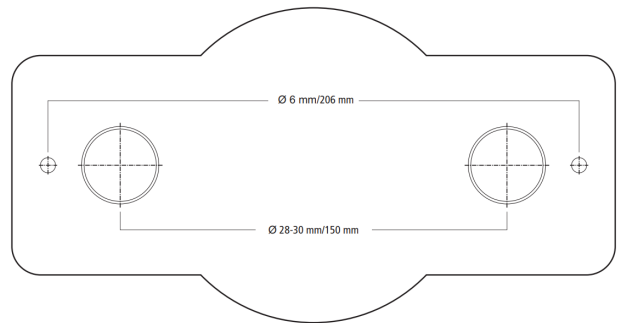

Tel: +44(0)1252 725257

Fax: +44(0)1252 727627

© 2018/19 LGM Products Ltd.

Email: sales@lgmproducts.com

Web: www.lgmproducts.com

ISO 9001:2015 certified

Address: LGM Products Ltd, Unit 15 Riverside Industrial Park, Farnham, Surrey, GU9 7UG, United Kingdom.