

Flame detector (UV/IR Type)
RFD-2000X User's Manual



TABLE OF CONTENTS

1 Product Overview

- 1.1 Product Introduction
- 1.2 Contents of User Manual
- 1.3 Revision of User Manual
- 1.4 Warranty

2 Technical Specifications

- 2.1 Electrical Specifications
- 2.2 Mechanical Specifications
- 2.3 Environmental Specifications

3 Installation

- 3.1 Unpacking & Checking
 - 3.1.1 Product Compositions
 - 3.1.2 Components
 - 3.1.3 Necessary tools
- 3.2 Selection of Installation Location
 - 3.2.1 Cone of Vision
 - 3.2.2 Range of Detection
 - 3.2.3 Environment points to be considered when use
- 3.3 Installation and Electrical Wiring
 - 3.3.1 Wiring Detector
 - 3.3.1.1 Conduit Installation
 - 3.3.1.2 Cable Selection for Electrical Wiring
 - 3.3.1.3 Conduit or Gland Standard (Connector)
 - 3.3.2 Using of bracket during installation
 - 3.3.2.1 Bracket Specification
 - 3.3.2.2 Installation of detector with bracket to the wall or the ceiling
 - 3.3.3 Terminal Wiring
 - 3.3.3.1 Relay Signal
 - 3.3.3.2 4-20mA (Current Source Wiring Contact)
 - 3.3.3.3 RS485
 - 3.3.3.4 External Recovery Signal Electrical Wiring
 - 3.3.3.5 Signal of Electrical wiring for external remote self-test
 - 3.3.4. Installation/Setting
 - 3.3.4.1 Sensitivity setting
 - 3.3.4.2 Setting of delay time
 - 3.3.4.3 Setting of others function
 - 3.3.5. Ground connection
 - 3.3.5.1 Internal Ground connection method
 - 3.3.5.2 External Ground connection method

4 Operation

- 4.1 Product checklist
- 4.2 Initial Operation of Product
- 4.3 Safety Handling
- 4.4 Product Testing

5 Maintenance & Troubleshooting Instructions

- 5.1 Tools of Maintenance and Products Training
- 5.2 Maintenance Procedures
- 5.3 Troubleshooting
 - 5.3.1 No LED responds after the power connection.
 - 5.3.2 Yellow LED blinking (2Hz)
 - 5.3.3 When receiver unable to detect various signal

6 Customer Support

- 6.1 Contacts Information

7 Appendix

- 7.1 Abbreviation
- 7.2 Choosing of Wiring
 - 7.2.1 Reference: Standard Chart for Power Supply Electrical Wiring during setting (AWG Standard)
 - 7.2.2 Things to be consider when choosing electrical wiring for power supply
- 7.3 Certification & Approvals

1. Product Overview

1.1 Product Introduction

Model RFD-2000X from Rezontech Co., Ltd. is UV/IR type flame detector. It activates alarm signal or fire extinguishing system via fire or flame detection. This function can be used directly with output terminal and through connected control circuits are also available. Various output methods are available for choice:

- Dry contact Relays (Fire, Fault, Warning)
- 4~20mA Current Output
- RS-485 Communication

RFD-2000X is a product with additional Internal/External recovery feature which enables to be widely used in difference applications.

1.2 Contents of User Manual

All the information about detectors and its features are described on this handling manual. its contents consist of 7 different sections as per stated on [Table 1] below .

Title	Content
1. Product Introduction	General introduction, products overview, brief introduction on each part
2. Technical Specification	Electrical, mechanical and environmental specifications
3. Installation	Wiring, mode select, proper installation
4. Operation	Operation mode and user interface display
5. Maintenance & Troubleshooting	Maintenance and technical support procedure
6. Customer Support	About This product will be customer service will describe the information
7. Appendix	Abbreviations, authentication, and parts will be describe information about products

[Table 1] Contents of User Manual

1.3 Revision of User Manual

Version	Date of Revision	Content	Remarks
1.0	March, 2010	Registration of document	
2.0	March, 2012	para# 2.2.2 3.2.2, 3.3.2, 3.3.4	amendment

[Table 2] Revision of User Manual

1.4 Warranty

Rezontech warrants the Models RFD-2000X to be free from defects in workmanship or material under normal use and service within two years from the date of shipment.

Rezontech will repair or replace without charge any such equipment found to be defective during the warranty period. Full determination of the nature of, and responsibility for, defective or damaged equipment will be made by Rezontech' personnel.

Defective or damaged equipment must be shipped to Rezontech' plant or representative from which the original shipment was made. In all cases this warranty is limited to the cost of the equipment supplied by Rezontech. The customer will assume all liability for the misuse of this equipment by its employees or other personnel.

All warranties are contingent upon proper use in the application for which the product was intended and does not cover products which have been modified or repaired without Rezontech' approval, or which have been subjected to neglect, accident, improper installation or application, or on which the original identification marks have been removed or altered.

Except for the express warranty stated above, Rezontech disclaims all warranties with regard to the products sold, including all implied warranties of merchantability and fitness and the express warranties stated herein are in lieu of all obligations or liabilities on the part of Rezontech for damages including, but not limited to, consequential damages arising out of, or in connection with, the performance of the product.

2. Technical Specifications

2.1 Electrical Specifications

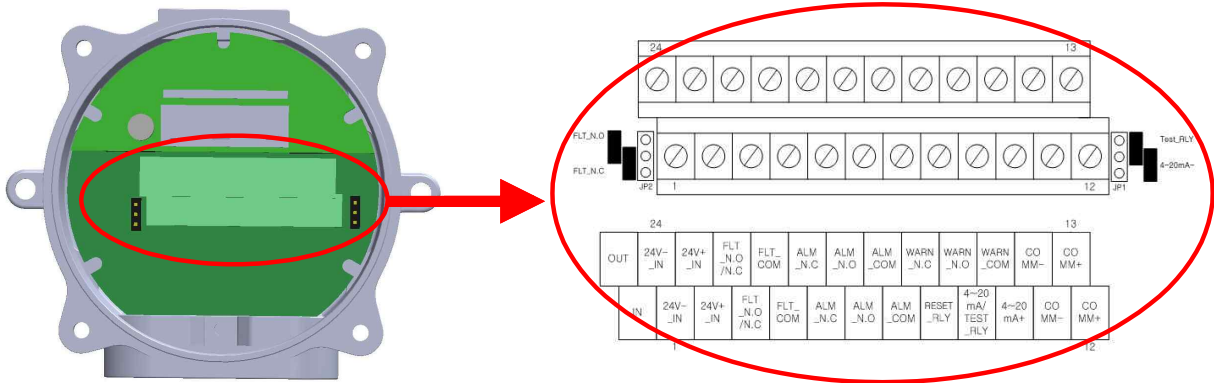

[Figure 1] TB1 Terminal address at product cover

2.1.1 Electrical

- Recommended Operating Voltage : 24VDC
- Rating Voltage : 17VDC ~ 32VDC
- Max Input Voltage : 36VDC
- Max Consumption Power : 1.8W (at 32VDC)
- Normal Average Current : approximate 35mA (at 24VDC)
- Max Operating Current : approximate 70mA
(at 17VDC, during detection of fire or self-diagnosis test)

2.1.2 Relay Output

- 2A 28VDC, 4A 125VAC, 2A 250VAC
- Dry Contact
- A(Normally Open) or B(Normally closed)

2.1.3 4~20mA Current Output

- Non-isolation output, Common 24V-_IN(-Power)
- Max. Terminating Resistance : 500Ω
- 0mA (+0.5mA) : Connection Fault
- 2mA (±0.5mA) : Self-diagnosis test Fault
- 4mA (±0.5mA) : Normal
- 8mA (±0.5mA) : IR Detection
- 12mA (±0.5mA) : UV Detection
- 16mA (±0.5mA) : Warning (UV and IR Detection, fire occurs during delay time)
- 20mA (±0.5mA) : Fire Detection

2.1.4 RS485 Communication

- Non-isolation output (2 wiring)
- Communication Speed : 9600bps

2.1.5 LED Indicator

- Two LED's(Yellow, Red) indicator
 - Yellow LED : Provides indication of Normal or Fault state
 - Red LED : Provides indication of Warning or Alarm state
- Product reset process : Yellow & Red LED intersection blinking repeatedly (3 sec)
- Normal : Yellow LED blinking (0.5Hz)
- Power supply or Self-diagnosis test fault : Yellow LED blinking (2Hz)
- Warning : Yellow LED blinking (0.5Hz) and Red LED blinking (2Hz)
- Alarm : Yellow LED blinking (0.5Hz) and Red LED lighting
- Warning at BIT Fault : Yellow LED blinking (2Hz) and Red LED blinking (2Hz)
- Alarm at BIT Fault : Yellow LED blinking (2Hz) and Red LED lighting

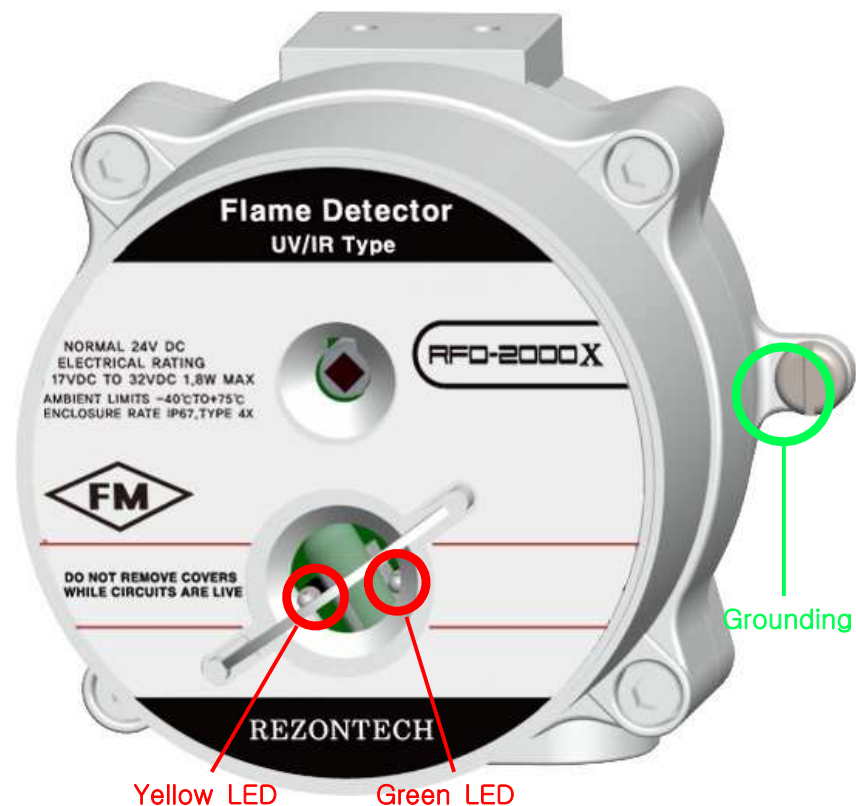

[Figure 2] Product Image LED position indicator

2.2 Mechanical Specifications

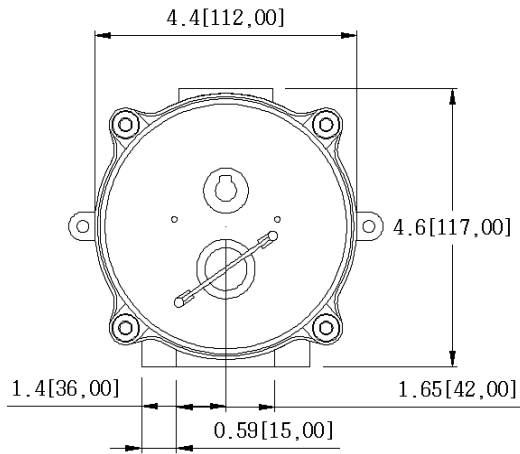

[Figure 3] Front, inch[mm]

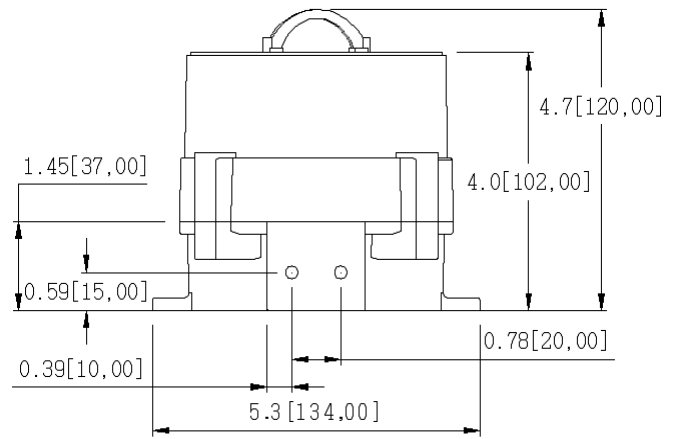

[Figure 4] Side, inch[mm]

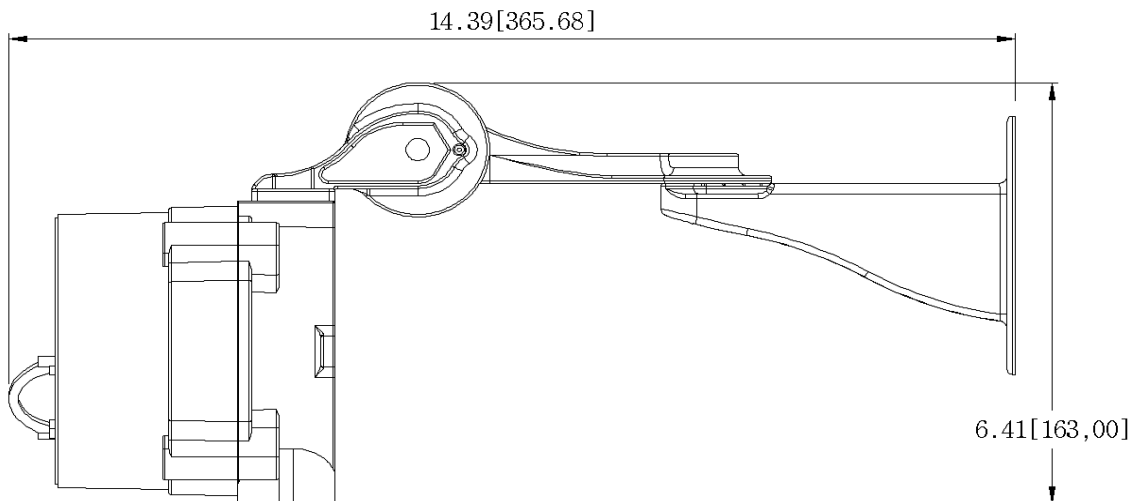

[Figure 5] Combination of Detector and Bracket, inch[mm]

- Enclosure (Material) : 316 Stainless Steel
- Weight : Body - approximate 2.4kg, Overall - approximate 3.4kg
- Dimension(Body) : W5.3[134] × H4.6[117] × D4.7[120] (inch[mm])
- Dimension(Overall) : W5.3[134] × H6.4 [163] × D14.4 [366] (inch[mm])
- Color : Metal
- Electrical connection (External) : 1/2 inch NPT-14, M20 X 1.5
- Wire gauge (Power supply & Signal) : AWG #14 (2.08mm²) ~ #24 (0.205mm²)
- Hazardous Area Approvals : Class I Div.1 Groups B,C and D
Class II Div.1 Groups E,F and G
Class III

- Explosion proof : ATEX Ex d IIB+H2 T6 (75°C)
- Water and Dust Tight : IP67, NEMA Type 4X

2.3 Environmental Specifications

- Operating Temperature : -40°C ~ +75°C
- Storage Temperature : -50°C ~ +80°C
- Humidity : Relative humidity 95%

3. Installation

3.1 Unpacking & Checking

Please check the external condition of detector when unpacking the product carefully. If there is any damage on the products, please contact the local distributor immediately or any trouble in used products, please send it to A/S center with fee applied.

3.1.1 Product Compositions

- RFD-2000X 1EA
- BK-2(Bracket) 1EA
- Spare Bolt 1set
- Tools

3.1.2 Components

3.1.2.1 Fundamental components

Component	standard	Q'ty (pcs)	Description
Hexagon wrench Bolt	M6×10	2	Join the Detector and Bracket
Hexagon wrench Bolt	M6×35 (OEM)	4	Join the Detector
Metric button screw (+)	M5×30	4	Install the Bracket

[Table 3] Fundamental components

3.1.2.2 Spare components

Component	Standard	Q'ty (pcs)	Description
Hexagon wrench Bolt	M6×10	2	Join the Detector and Bracket
Hexagon wrench Bolt	M6×35 (OEM)	4	Join the Detector
Metric button screw (+)	M5×30	4	Install the Bracket

[Table 4] Space Components

3.1.3 Necessary tools

Tool name	Standard	Q'ty (pcs)	Description
Hexagon wrench driver	Metric,5M	1	Join the detector, bracket
Screw driver	+	1	Install the Bracket

[Table 5] Necessary tools

3.2 Selection of Installation Location

Minimum information will be provided below for the location selection of installation. Please refer the information according to the purpose of your use.

3.2.1 Cone of Vision

3.2.1.1 Fuel

- N-Heptane

3.2.1.2 Cone of Vision

- Horizontal / Vertical : 90° (45° up, down, left, right at 50% of detection range)

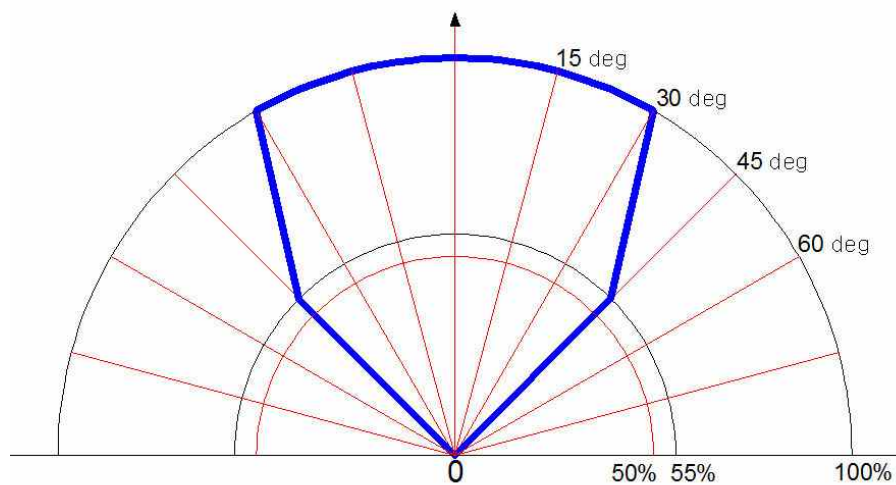

[Figure 6] Cone of Vision

3.2.2 Range of Detection

The detection distance for the alarm level is 98.5 ft(30 m) from the standard fire.

The detector has two response levels.

- Warning
- Alarm

3.2.2.1 Detection Range of Fuels

Type Of Fuel	Maximum Distance (ft / m)
N-Heptane	98.5 / 30

[Table 6] Range of Fuels Detection

3.2.2.2 Detection Range of False Alarm

The detector is immune to a variety of false alarm sources. Representative samples of detector's response from false alarm sources are listed below.

Radiation Source	Immunity Distance ft(m)
Indirect or reflected sunlight	No fire alarm
Incandescent lamp 100W	No fire alarm
Fluorescent light 40W	No fire alarm
Resistive electric heater 1500W	No fire alarm
Blue, Green dome light XXXW	No fire alarm
Hot plate (200°C)	No fire alarm
Halogen lamp 500W (Glass)	No fire alarm
Halogen lamp 1000W (Quartz lamp)	12 (4)
Grinding metal	3.3 (1)
Arc welding (5mm, 200A)	15 (4.6)

[Table 7] Types of False Alarm source and Its Relationship between Flame Detection

3.2.3 Environment points to be considered when use

- Installation places and availability of fuels (Family of Hydrocarbon and related flame detection)
- install product according to its Installation space and it areas of dangerous (internal/external etc)
- Select place of installation according to detection range and field of view
- Temperature range [Min/Max] of operation/installation
- Select the place to avoid the area with obstructed object for the appropriate installation
- Select the place to avoid the area with false alarm statuses affect to the fire detection

※ The above points of considerations are based on the basic environmental standard and they are vary different between countries in terms of environment, usage, users etc.

3.3 Installation and Electrical Wiring

3.3.1 Wiring the Detector

3.3.1.1 Conduit installation

- Use 1/2 inch NPT-14 or M20X1.5 conduit connection or suitable explosion-proof gland to assemble the cable and conduit to the detector.
- When using conduit connection for Division installation, conduit seals must be installed within 18 inches (450mm) from the enclosure.
- When using conduit connection for ATEX installation, conduit seals must be placed at enclosure.
- Install the conduit including drain holes place downward to avoid water condensation in the detector.

3.3.1.2 Cable Selection for Electrical Wiring

- All cables to the detector should be well shielded for EMC.
- Wire gauge for detectors power supply wires.

AWG No.	Diameter(mm)	Cross section(mm ²)
24	0.511	0.205
23	0.573	0.258
22	0.644	0.326
21	0.723	0.410
20	0.812	0.653
19	0.912	0.653
18	1.02	0.823
17	1.15	1.04
16	1.29	1.31
15	1.45	1.65
14	1.63	2.08
13	1.83	2.63
12	2.05	3.31

[Table 8] American Wire Gauge Standard

3.3.1.3 Conduit or Gland Standard (Connector)

- Cable Conduit Standard : 1/2 inch NPT-14, M20 X 1.5
- Water and Dust : IP67, NEMA Type 4X

3.3.2 Using of bracket during installation

3.3.2.1 Bracket Specification

- Angle adjustment : Horizontal 180° , Vertical 180° , scale indications 15° each
When you arrange the angle, M4 Set Screw and M10-25 Hexagon Wrench Bolt has to be released first and tighten again with 24 (N·m) Torque for Hexagon Wrench Bolt and 1.5 (N·m) Torque for Set Screw.
- Enclosure Material : 316 Stainless Steel
- Weight : Body - approximate 2.4kg, Overall - approximate 3.4kg
- Dimension(Body) : W5.3[134] × H4.6[117] × D4.7[120] (inch[mm])
- Dimension(Overall) : W5.3[134] × H6.4 [163] × D14.4 [366] (inch[mm])
- Color : Metal
- Wall mounted size : 6Φ × 4 (5mm bolt)

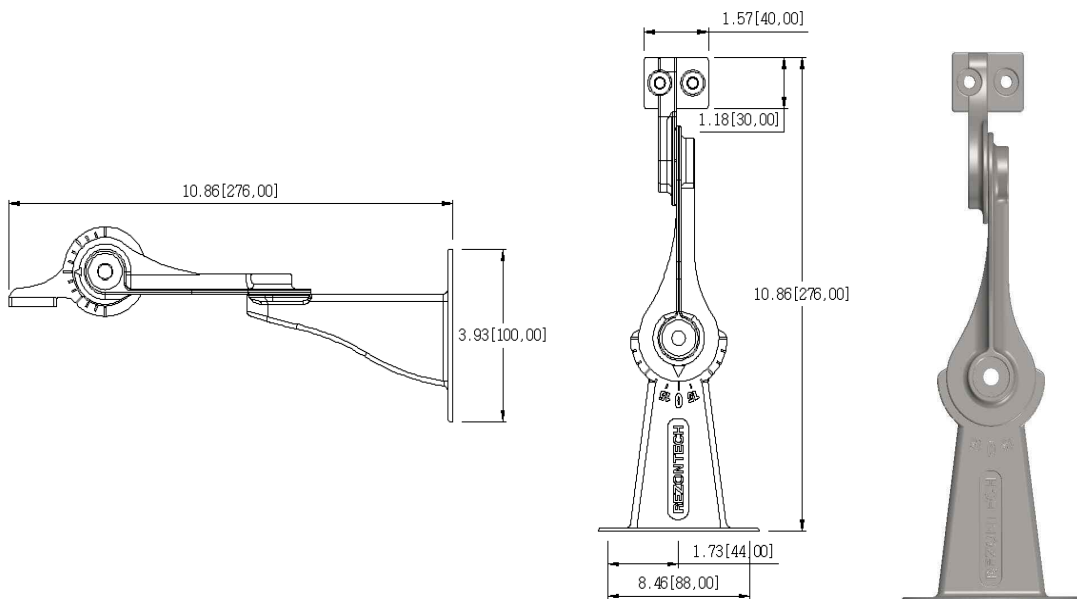

[Figure 7] Bracket BK-02

3.3.2.2 Installation of detector with bracket to the wall or the ceiling

- Necessary tool : Hexagon Wrench Driver, Screw Driver
- component : Metric M6-10 × 2 pcs, Metric M5-30 × 4pcs
- Flame detector's body and cover has to be combined with M6-35 Hexagon Wrench Driver at 5(N·m) Torque.
- Flame detector and bracket is connected with Hexagon Wrench Bolt at 5(N·m) Torque.

- Mount the bracket with M5-30 × 4pcs bolts. Refer to Figure 17
- Detector can be installed on the wall or the ceiling with bracket. Refer to Figure 18, 19

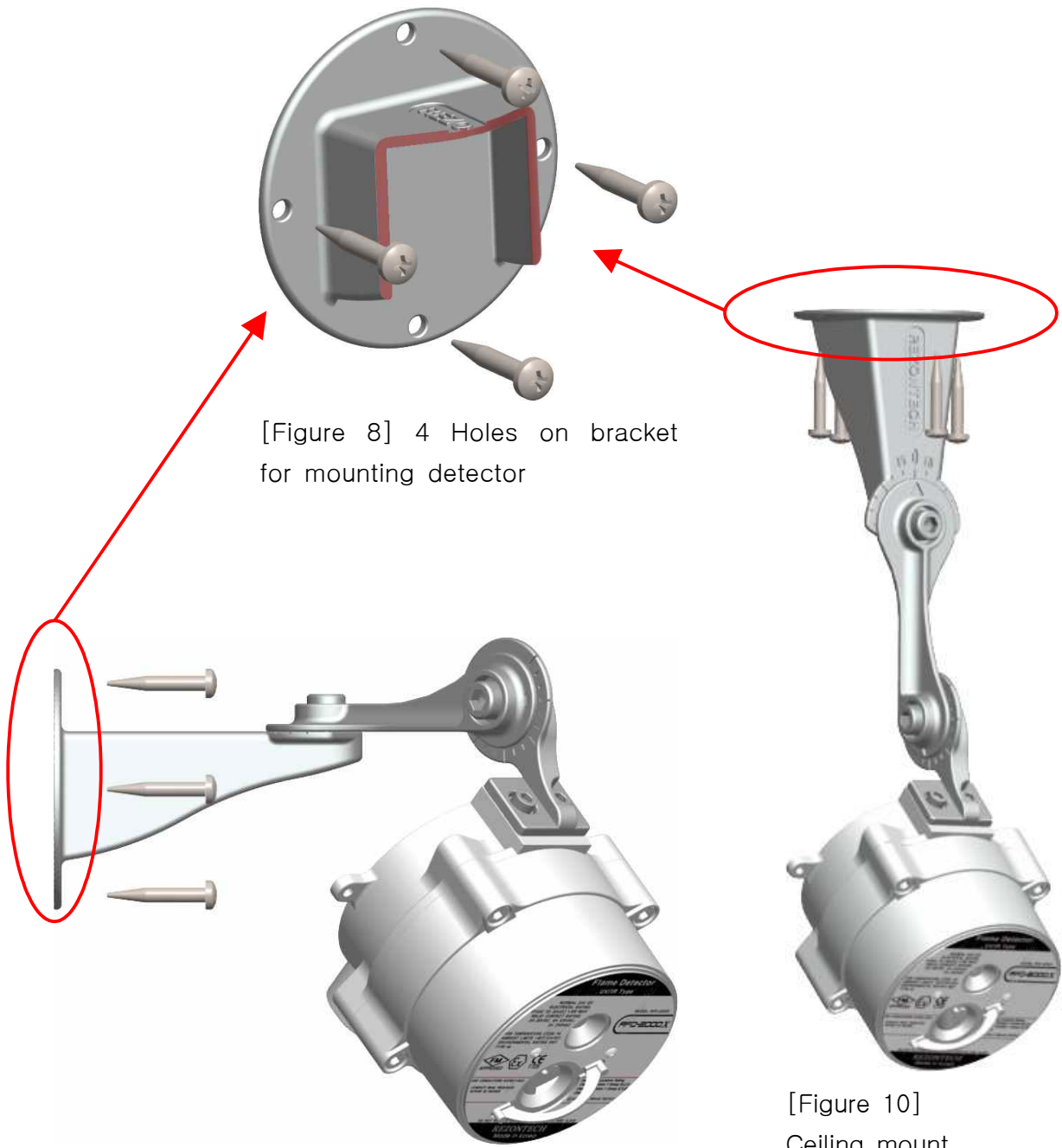

3.3.3 Terminal Wiring

This is the reference for the user on how all the connection of the electrical wiring are connected to each system or product as per stated below.

3.3.3.1 Relay Signal

- Fire Relay

The following signal occurs when fire is detected

- The operational status of fire relay according to detector's condition.

TB1	Fire Relay	Relay status	
		Normal (De-Energized)	Fire (Energized)
5,20	ALM_N.C	Closed	Open
6,19	ALM_N.O	Open	Closed
7,18	ALM_COM	Common	Common

- 2A@28VDC, 4A@125VAC, 2A@250VAC

[Table 9] Fire Relay operated

- Interlink wiring of Power Supply, Fire Relay, Fault Relay

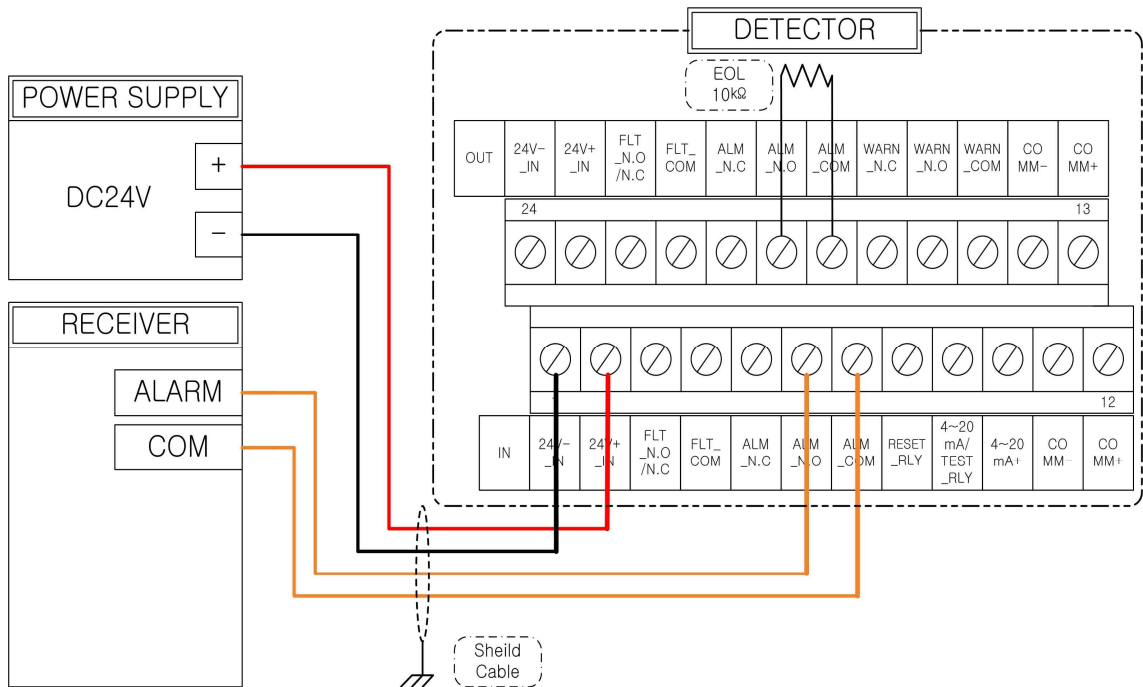

[Figure 11] Terminal wiring diagram schematic at fire alarm relay

- Fault Relay

This signal shows up when product is not working properly or the fire signal is not functional.

※ Before power supply is on, FLT_N.O is connected because Fault Relay is not in error status.

· Fault Relay Operated

Type of Fault	Descriptions
Power Supply	The error status of external and internal power supply
Self Testing	The error status of basic function (fire detection)

[Table 10] Fault Relay Operated

· Fault Relay operated according to detector's condition

TB1	Fault Relay	Relay Status	
		Normal (Energized)	Fault (De-Energized)
3,22	FLT_N.C	Open	Closed
3,22	FLT_N.O	Closed	Open
4,21	FLT_COM	Common	Common

- 2A@28VDC, 4A@125VAC, 2A@250VAC

- Change Fault Relay's FLT_N.O/N.C mode accordingly by switching the jumper.

- FLT_N.O is available by default

[Table 11] Fault Relay Operating Status

- Power supply Fire, Relay and Fault Relay wires interlink (indication of Jumper setting location)

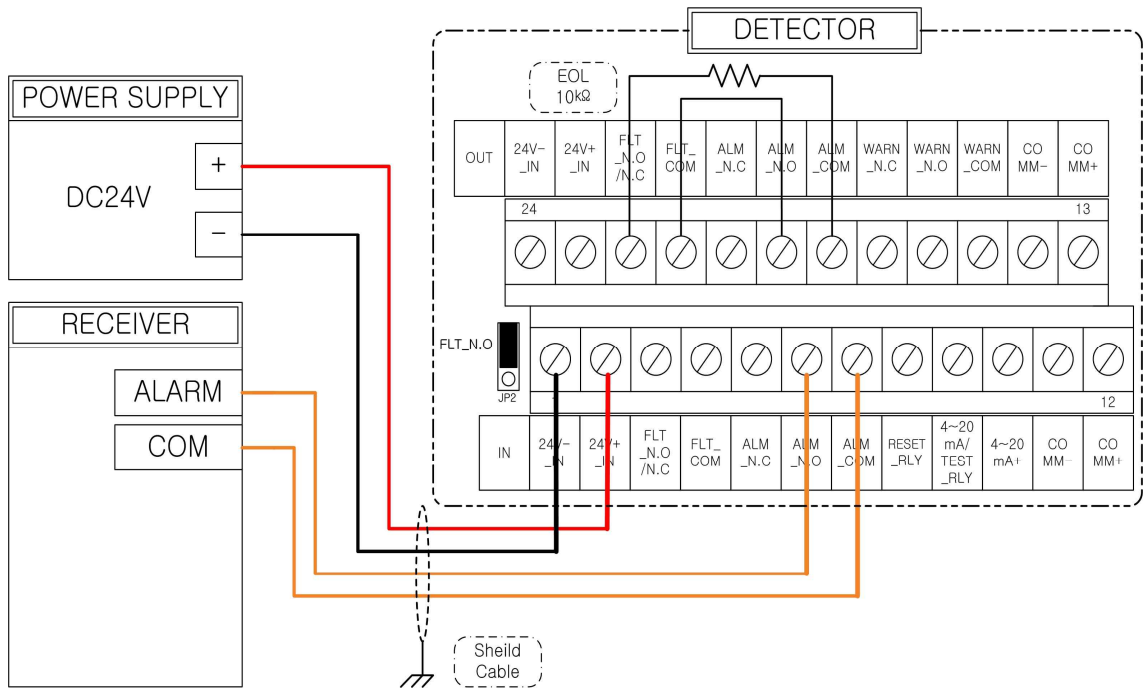

[Figure 12] Terminal wiring diagram schematic at fault relay (Internal)

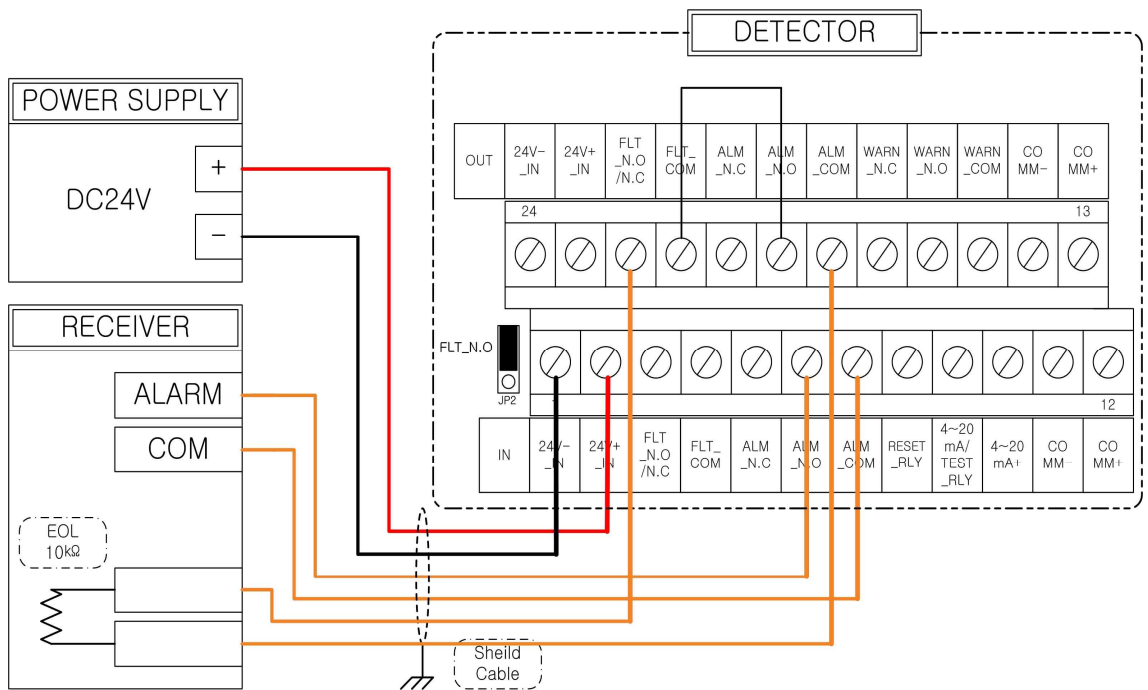

[Figure 13] Terminal wiring diagram schematic at fault relay (External)

- Loop connection with several detectors

This is Loop type connection method which can generate alarm and fault signal. But with this connection, detection performance is blocked when one flame detector is in fault condition. So this method is only available with specific receiver which can check fault signal frequently and automatically.

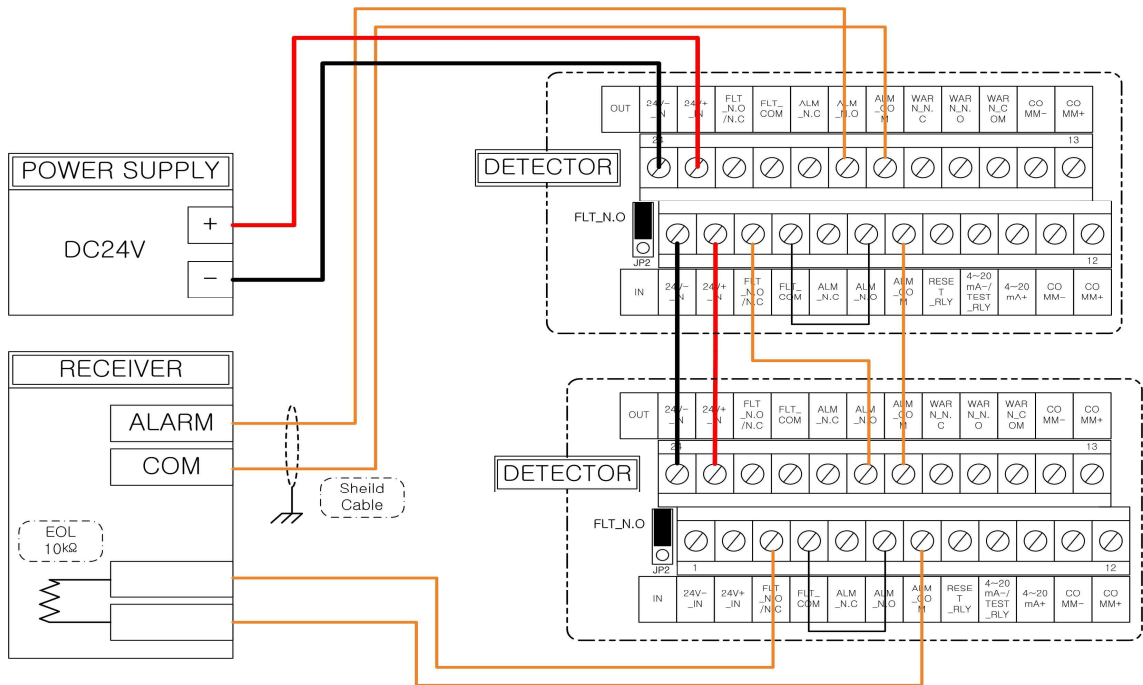

[Figure 14] Terminal wiring diagram schematic for LOOP connection

- Warning Relay

This signal shows when fire is detected at primary stage before the real fire is confirmed. This signal only occurs within delay time.

- Warning Relay operated according to detector's condition

TB1	Warning Relay	Relay status	
		Normal (De-Energized)	Warning (Energized)
17	WARN_N.C	Closed	Open
16	WARN_N.O	Open	Closed
15	WARN_COM	Common	Common

2A@28VDC, 4A@125VAC, 2A@250VAC

[Table 12] Warning Relay Operating Status

- Interlink electrical wiring of Power supply Fire Relay, Fault Relay, and Warning Relay

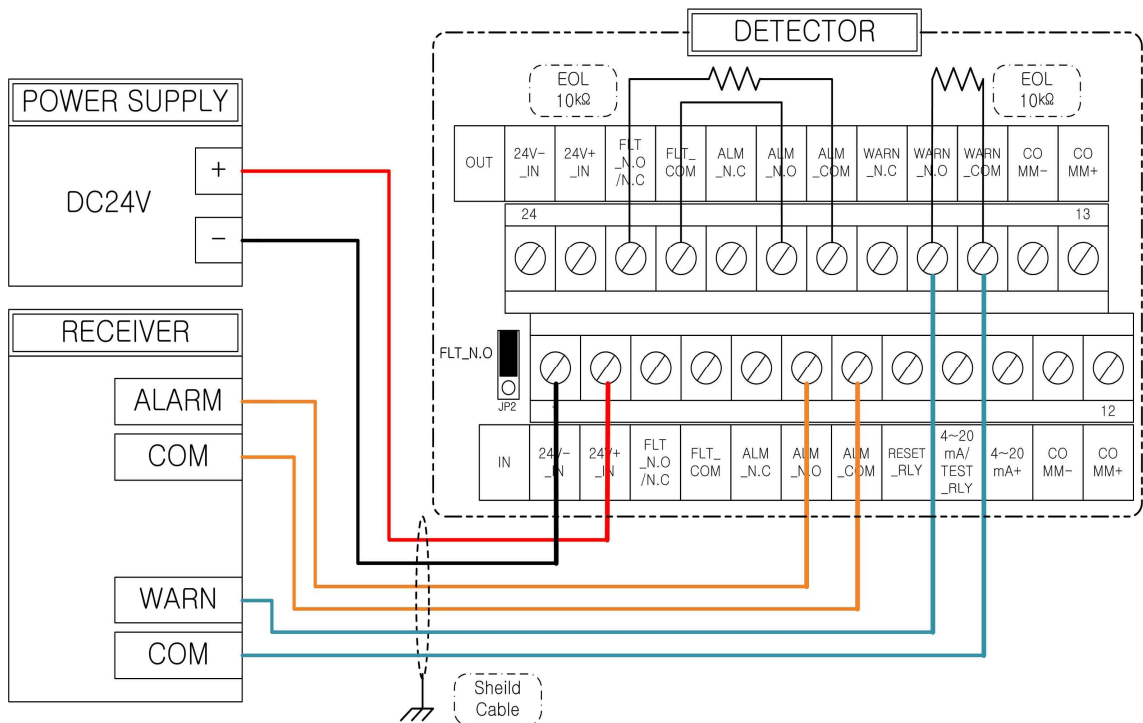

[Figure 15] Terminal wiring diagram schematic at fault and warning relay

3.3.3.2 4~20mA (Current Source)

This signal shows when various recorded information of current output is transmitted through electrical wiring. It is varied according to the product status.

- Non-isolation output, Common 24V-IN (-Power)
- Max. Terminating Resistance : 500Ω

- Types of Signal

- 0mA (+0.5mA) : Connection Fault
- 2mA (±0.5mA) : Self-Diagnosis test Fault
- 4mA (±0.5mA) : Normal
- 8mA (±0.5mA) : IR Detection only
- 12mA (±0.5mA) : UV Detection only
- 16mA (±0.5mA) : UV and IR Detection (Warning)
- 20mA (±0.5mA) : Fire Detection

- Signal of electrical wiring (3 Lines-Sourcing)

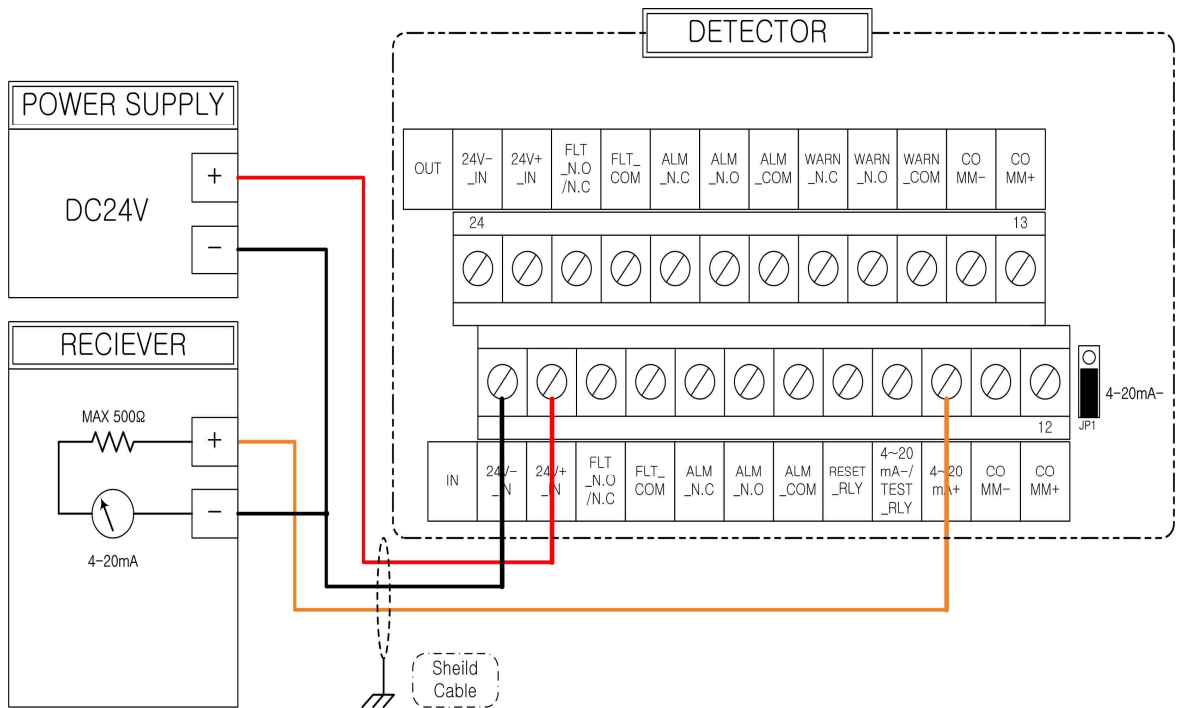

[Figure 16] Terminal wiring diagram schematic at 4~20mA output

3.3.3.3 RS485

This signal (RS485) does not inform product status only but also supports changing and controlling in variable setting value. And this function can be used in synch with interlinking remote control or other systems.

Signal terminal number (TB1)	
TB1	Signal name
11	COMM-
12	COMM+
13	COMM+
14	COMM-

[Table 13] TB1 communication terminal number

- Communication Specification

- Non-isolation communication
- Full-duplex, half-duplex
- 9600bps basic setting
- 1:N support (Client)
- support protocol : manufacturer protocol

- Signal of Electrical Wiring

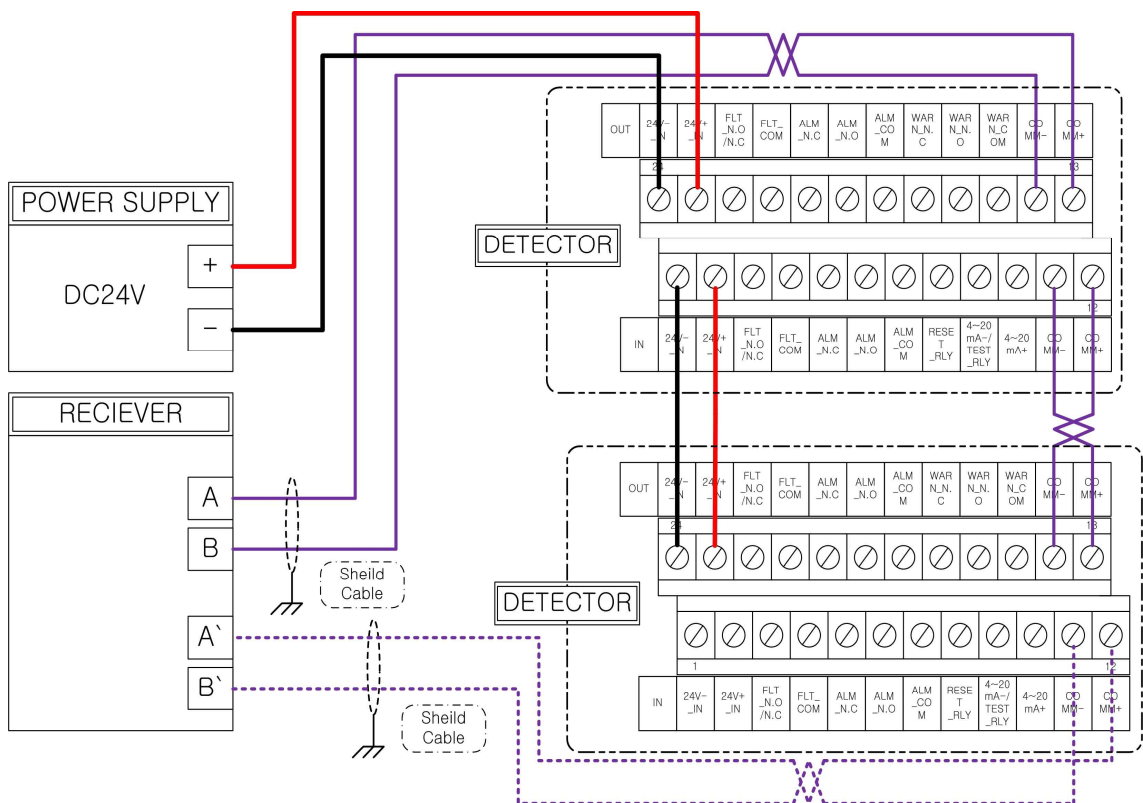

[Figure 17] Terminal wiring diagram schematic at RS-485 communication

3.3.3.4 External Recovery Signal

It is used when the detector needs to recover from its default status after any fire detection, etc. Hence, it is similar to reset product via power on/off.

Signal terminal number (TB1)	
TB1	Signal name
8	RESET_RLY

[Table 14] TB1 External recovery signal terminal number

- Signal Specification

- Operating Signal : same level of signal with 24V_IN
- Operating delayed time : 5 seconds
- Operating continuous time : after cancelling operating signal + reset time
- ✘ After using the function above, signal must be opened first for the proper operation.

- Signal of electrical wiring

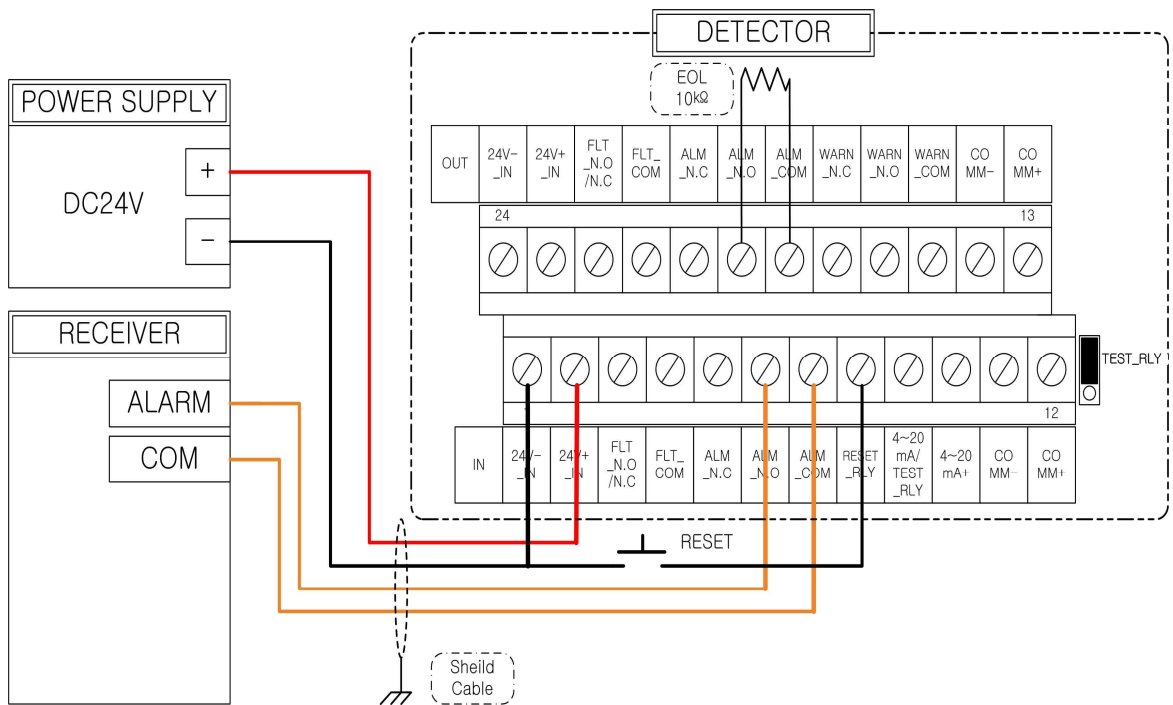

[Figure 18] External recovery signal electrical wiring diagram

3.3.3.5 External Self-Diagnosis Test

Within the various parts of fire detector, sensor is the most basic receiving part nearest from 'fire signal' with transmission function. This function is enable to inspect from the receiving part to fire recognition circuit.

Signal terminal number (TB1)	
TB1	Signal name
No.9	TEST_RLY

Change JP1's jumper to TEST_RLY

[Table 15] TB1 Terminal number for external self-test signal

- Signal Specification

- Operating signal : same level of signal with 24V-IN
- Operating delayed time : 5 seconds
- Operating continuous time : operating delayed time + 10 secs. (approx. 20 secs.)
- The result of signal

Result signal	
Normal	Fault
Normal output for all signals	<ul style="list-style-type: none"> - Fault Relay output (De-Energized) - 2mA (±0.5mA) : self-test error signal - Yellow LED blinking (2Hz) - Response of communication self-test faulty signal

[Table 16] External self-test signal table

- Signal of electrical wiring

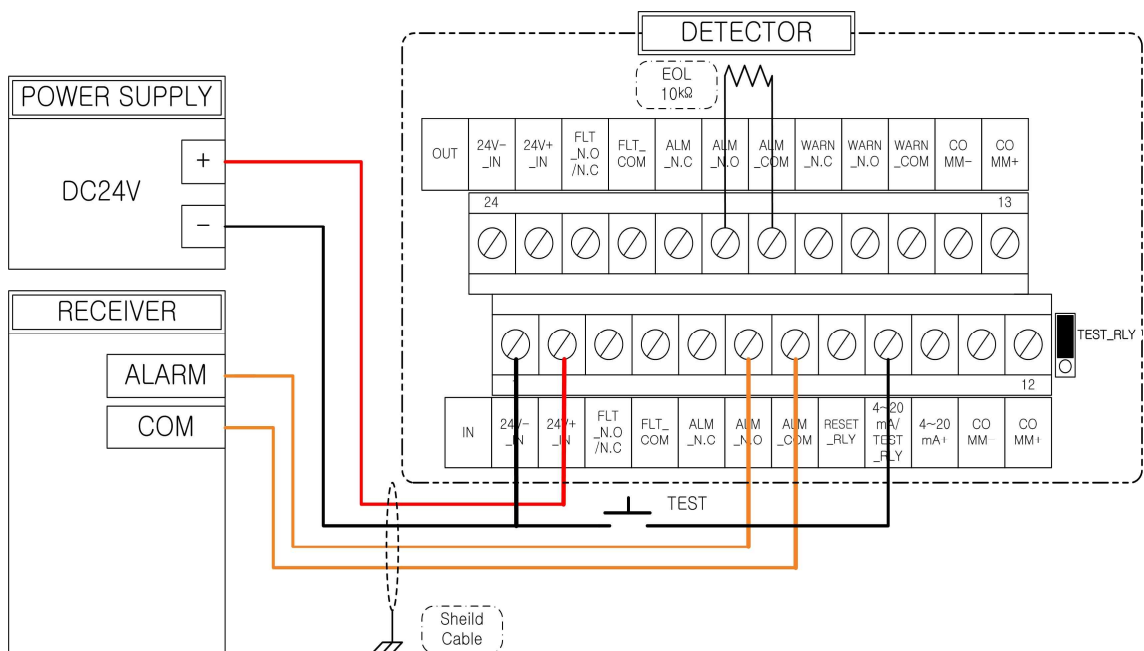

[Figure 19] External self-test signal External self-test

3.3.4 Setting of Product

3.3.4.1 Sensitivity setting

Sensitivity setting can be adjusted by user according to the various environmental conditions. Due to the difference in law or regulation from various countries, this function may not be applicable to all. So we have no responsibility for the troubles related with sensitivity setting over the approved range.

- FM Approval response range : No.3 of SW1, OFF("0")
- FM Approval does not allow : No.3 of SW1 ON("1")

- Setting method of sensitivity

Do not set the switch, while power is applied. The switch adjustment with power connection will not be recognized by the detector.

- The sensitivity of No. 3 at SW1, OFF("0")

SW1				
Switch setting			Sensitivity	Range of Sensitivity ft(m)
No.3	No.1	No.2		
0	X	X	-	98.5(30)
0	X	X	-	98.5(30)
0	X	X	-	98.5(30)
0	X	X	-	98.5(30)

[Table 17] Sensitivity range of N-Heptane

- The sensitivity of No.3 at SW1, ON("1")

SW1				
Switch setting			Sensitivity	Range of Sensitivity ft(m)
No.3	No.1	No.2		
1	0	0	Low	60(18)
1	1	0	Middle-1	65(20)
1	0	1	Middle-2	82(25)
1	1	1	High	98.5(30m)

- Reference Source of fire standard is 70cm×70cm of N-Heptane
- FM Approval does not allow

[Table 18] Sensitivity range of N-Heptane

3.3.4.2 Setting of Delay Time

The flame detectors are equipped with Alarm delay option, which provides programmable time delays by settings. The Alarm signal will be activated if the fire still exists after programmed delay time. But the fire disappears within programmed delay time, the detector will return to its standby state again.

The Alarm delay option affects the output relays and the 0-20mA. The LEDs and outputs indicate warning levels during the delay time only if the fire condition exists.

SW1			
Switch setting			Delay time
No.4	No.5	No.6	
0	0	0	1
1	0	0	3
0	1	0	5
1	1	0	8
0	0	1	10
1	0	1	15
0	1	1	20
1	1	1	25

[Table 19] Switch setting for delay time

※ When setting of delay time to 5, an average response time is about 12 second for 1X1 feet heptane pan flame at 98.5 feet (30 m) from FM approval results.

3.3.4.3 Setting of Others Function

- Setting of Alarm Signal Latch

This is the recovery signal when source of fire is disappear or setting is out of range. This supports two kinds of setting. First, user can recovery fire detector through powering "OFF" and "ON" manually or using "RESET_RLY" terminal. Second, it recoveries automatically in 5 seconds if status of fire detection signal is cancelled.

SW1	
Switch Setting	Function
No.7	
0	Automatic Recovery "OFF"
1	Alarm Latch "ON"

[Table 20] Switch setting for recovering signal of fire detection

- Setting of Self Checking Function

After the appropriate installation, the detector performs self diagnostic test by itself from the internal sensor to circuit repeatedly.

SW1	
Switch Setting	Function
No.8	
0	Self testing function "OFF"
1	Self testing function "ON"

- Period of self testing : Every 12 hours

[Table 21] Switch setting for self-diagnosis test

3.3.5 Ground Connection

For proper operation of the detector, the RFD-2000X must be grounded through a wire to the chassis.

Failure to establish a ground connection can lead to greater susceptibility of the detector to electric surges, electromagnetic interference, and ultimately, damage to the instrument.

3.3.5.1 Internal Grounding Method

Connect Hole in the internal "Board01" and PCB to enclosure connection bolt with electrical line.

3.3.5.2 External Grounding Method

Ground with connection line located in right side of enclosure.

4. Operation

The contents of this page are about "Operation". As much as 'product selection' or 'Installation', the operation is also very important. Though another parts of operation "Maintenance and Troubleshooting" will be discussed separately in another chapter.

- Product Inspection
- Initial Operation of Product
- Safety Handling
- Product Testing

4.1 Product Inspection

For the appropriated operation after the installation, the essential information for inspection will be described below.

4.1.1 Inspection of Installation conditions

If there are any inferior or bad installation, Reinstallation can be recommended. This minimum inspection can affect to the duration and performance of the products.

- Product Fixing Conditions
- Inspection of Product Assembly Conditions (Internal Wiring and Joins)
- Installation height and angle of different products are vary accordingly.
- The conditions of product after combination with others product.
(Explosive-proof and water proof, other electrical conditions)

4.2 Initial Operation of Product

The product operation will be explained below under the assumption that all the required wiring, such as main power supply(24VDC) or signals is connected properly.

Initial Operation	
Status	Operate or Output Status
Before inserting power supply	- Fault Relay signal Open (Normally Open : De-Energized) - All LED OFF
After inserting power supply	Com mon - Fault Relay signal Closed (Normally Closed : Energized) - After 7 seconds of self-diagnosis test, LED intersect for 3seconds (Yellow → Red → Yellow.....) blinking
	Normal - All output, "normal" signal output (Normally Closed : Energized) - YELLOW LED blinking 0.5Hz
	Fault - Closed of Fault Relay signal (Normally Closed : De-Energized) - LED "Fault" signal output - Current "Fault" signal - Communication "Fault" signal

[Table 22] Initial Operation of Product

4.3 Safety Handling

There are a few points to be taken note when the products are used with the power connection.

- Please refer to the diagrams and specifications on the user manual
- Do not open the product while the power supply is 'On', especially in dangerous area, further cautions are needed more.
- Disassembly and assembly of the internal electrical parts of the product are not allowed to anyone, except the manufacturer. Unauthorized action within the internal electrical parts will expire the warranty.
- When trying to detached the product from its installed place (including full system), advanced checking for interrelation with related system must be placed to avoid malfunction.

4.4 Product Testing

4.4.1 Product Testing by using : TL205

TL 205 generates specific UV/IR radiations which can be detected by Rezontech Flame detector series as fire. It has an individual built in internal power supply hence, it can be moved and used easily. It can be continuously working up to 30 minutes. For more details kindly refer to the user manual.

※ If everything is fine without any problem during the testing period by using the test lamp, the flame detector will generate actual fire alarm signal which can activate all related fire fight system, so appropriate preparation and inspection must be placed before the test with TestLamp.



[Figure 20] TL205 TEST LAMP

· Testing Sequences with TL205

1. Please wait for 10seconds after the power is supplied. Check, Yellow LED blinking.
2. Face and 'Turn On' the TL 205 in front of the flame detector.
3. The recommended distance between test lamp and product shall be within 5M when point no. 2 above is performed.
4. If "Red LED" is lighting on the flame detector, fire is detected generally.
5. If the product is set to be recovering manually, the recovery will be start by turning OFF/ON of the power supply
6. If "Red LED" does not light on during the test stage 2,3, please adjust the distance and re-test again. If the same problem persists and even after the TestLamp is in good conditions after the inspection (as per below stated), please contact the manufacturer or A/S center. The flame detector might have defects.

Scope of Inspection	
Power supply status checking	- TestLamp's No.1 or No.2 lamp is not functioning, it means the TestLamp is defected. - If TestLamp's lamp No.1 is blinking and the radiation intensity is weak, or if it's No.2 lamp is not functioning, please re-charge the TestLamp.

[Table 23] Lighting Status of Test lamp

Product Operation Status Vary According to Testing Conditions		
Status	Operate or Output Status	
Before inserting power supply	- Fault Relay signal Open (Normally Open : De-Energized) - All LED OFF	
After inserting power supply	Inserting	- Fault Relay signal Closed (Normally Closed : Energized) - After 7 seconds of self-diagonosis test, LED intersect for 3seconds (Yellow → Red → Yellow.....) blinking
	Normal	- All output, "normal" signal output (Normally Closed : Energized) - YELLOW LED blinking 0.5Hz
	Fire	- All output "Fire" signal

[Table 24] Product Operation Status Vary According to Testing Conditions

5. Maintenance and Troubleshooting

This chapter deals with preventive maintenance, describes possible faults in detector operation and indicates corrective measures. Ignoring these instructions may cause problems with the detector and may invalidate the warranty. Whenever a unit requires service, please contact rezontech or its authorized distributor for assistance.

5.1 Tools of Maintenance and Products Training

Basic tools are necessary and the person in-charge shall received products training in order to maintain the detector. The setting issues and its related issue, regulations shall be well trained or familiar with.

5.2 Maintenance Procedures

5.2.1 Clean the detector

The detector must be kept as clean as possible. Clean the viewing window and the reflector of the Flame Detector periodically. The frequency of cleaning operations depends upon the local environmental conditions and specific applications. the early fire detection system designer or fire fight system designer can give his/her personal recommendation.

1	Disconnect power to the detector before proceeding with any maintenance including window/lens cleaning.
2	Use detergent liquid for view window on detector, and must rinse it with clean water.
3	Where dust, dirt or moisture accumulates on the window, first clean it with a soft brush. and use detergency soft optical cloth. and then rinse it with clean water.

5.2.2 Periodic Maintenance Procedures

The cleaning for prevention must be performed from time to time. And the operation test must be also performed every 6 months. This test must be performed after the output signal was blocked.

5.2.3 Maintenance Recording

Please record the maintenance process for the detector in the maintenance book. Device name, date of installation, name of supplier and other necessary information must be recorded accordingly. If there are any service needed, the maintenance record should be sent together to the respective parties for reference.

5.3 Troubleshooting

If there is any error, kindly refer to the solutions as stated below. And please contact the manufacturer or authorized A/S center if the problem proceed.

5.3.1 The LED is not responding after the power supply is connected.

- Check the product is combined rightly or not.
- Check the product is connected with the appropriate power supply polarity.
- Check the power supply connection to the product is within the proper voltage range or not.
- Check the internal short occurs due to the foreign substance.

5.3.2 Yellow LED blinking (2Hz)

- Check the input voltage of the product. Check the operation range.
- The product connector might be polluted by foreign substances during the combination. Please check the internal connector.
- If input voltage is appropriate, please contact the manufacturer or authorized A/S center. Because the defect is caused by internal operating voltage or fire detection circuit.

5.3.3 When the receiver is unable to detect various signal

- Check the product is combined rightly or not.
- Check whether the wiring connection is right or not, according to the user manual.
- All fire related signal can be measured right after the fire signal's detection. Check the signal is measured or not after the fire signal.
- Check the electrical wiring is cut off or well connected.
- Check the jumper setting for 4~20mA current output is correctly set or not.

6. Customer Support

6.1 Contacts Information

Rezontech Office

Address	Phone, Fax, E-Mail
South Korea 805, Megavally, Gwanyang-dong, Dongan-gu, Anyang-si, Gyeonggi-do, Korea	TEL : +82-1544-9108 FAX : +82-31-420-0800 E-Mail : rezontech@rezontech.com

[Table 25] Information of Contact

7. Appendix

7.1 Abbreviation

Abbreviation	Description
ATEX	Atmosphere Explosives
AWG	American Wire Gauge
EOL	End Of Line
FOV	Field Of View
IECEX	International Electrotechnical Commission Explosion
IR	Infrared
UV	Ultraviolet
Latching	Refers to relays remaining in the ON state even after the ON condition has been removed
LED	Light Emitting Diode
mA	Milli Ampere (0.001 ampere)
N.C	Normally Closed
N.O	Normally Open

[Table 26] Various Types of Abbreviation

7.2 Choosing of Wiring

Kindly consider the electric wiring standard as stated below during the product wiring.

7.2.1 Standard Chart for Power Supply Electrical Wiring during setting (AWG Standard)

AWG #	mm ²	Max. Resistance Value at 68°F (20°C)	
		Ohm per 100m	Ohm per 100ft
24	0.16 ~ 0.24	11.22	3.42
22	0.30 ~ 0.38	5.60	1.71
20	0.51 ~ 0.61	3.50	1.07
18	0.81 ~ 0.96	2.20	0.67
16	1.22 ~ 1.43	1.40	0.43
14	1.94 ~ 2.28	0.88	0.27
12	3.09 ~ 3.40	0.55	0.17

[Table 27] Standard of Electrical Wiring

7.2.2 Things to be consider when choosing electrical wiring for power supply:~

- The number of product to connect to one circuit
- Wiring length for installation (overall space or partly space)
- The necessary voltage range for product
- The minimum range of power supply voltage
- Setting of electrical wiring in order for the product to function
- Ambient temperature

7.3 Certification

- FM 3260, May 2012
- ATEX CE1725 Ex II G, Ex d IIB+H2 T6 ($-40^{\circ}\text{C} \leq T_a \leq +75^{\circ}\text{C}$)