



ATEX 

## Duct Smoke Detector LRS 04 Ex

Manual

October 2010

# Content

Content .....	2
1 Introduction .....	4
2 About this document .....	5
2.1 Objectives and intended readers .....	5
2.2 Symbols used .....	5
3 Safety.....	6
3.1 Guarantee claims .....	7
4 Project planning .....	8
5 Technical data.....	9
6 General information .....	11
6.1 Operation of the LRS 04 Ex.....	11
6.2 Transport, storage and unpacking .....	11
6.3 Scope of delivery .....	11
7 Rules and regulations.....	12
7.2 Safety in potentially explosive atmospheres .....	13
7.3 Intended use.....	13
7.4 General safety information and protective measures .....	14
7.4.1 Explosion-protection regulations .....	14
7.4.2 Classification of hazardous areas .....	17
8 Product description.....	18
8.1 Design and mode of operation of LRS 04 Ex.....	18
8.1.1 Terminal assignment in the connection box of the LRS04 Ex .....	20
8.2 Device functions and display elements of the LRS 04 Ex.....	20
8.3 Accessories for the LRS 04 Ex.....	21
8.3.1 Power supply and tripping unit NAG 03 .....	21
8.3.2 Signal and display control element SAB 04.....	24
8.3.3 Manual actuation pushbutton 422 Ex .....	24
8.3.4 Connection box Ex.....	25

- 8.3.5 Smoke switch condition indicator RZA 142.....26
- 9 Installationdirections.....27
  - 9.1 Mechanical installation of the LRS 04 Ex.....27
  - 9.2 Electrical connection.....30
  - 9.3 Switching examples .....34
- 10 Commissioning.....37
  - 10.1 Functional testing .....37
  - 10.2 Servicing .....38
  - 10.3 Display of operating statuses of the ORS 221 Ex .....39
- 11 Provisions for maintenance and servicing.....40
- 12 Ordering data.....41**

# 1 Introduction

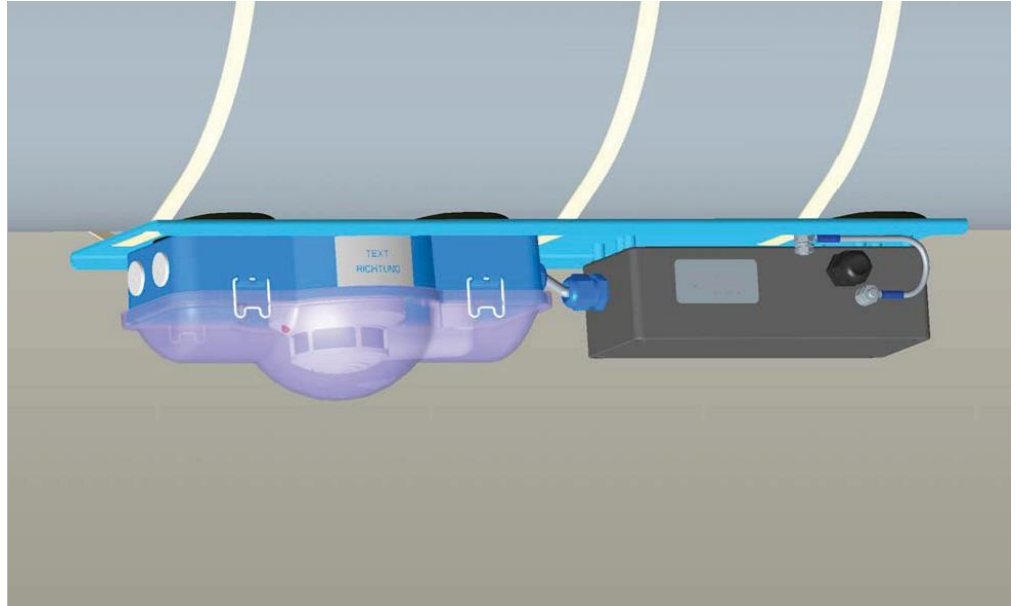

Fig. 01 LRS 04 Ex

The Duct Smoke Detector LRS 04 Ex comprises the ventilation duct base LKS 02, the optical smoke switch ORS 221 Ex and the ORS 142 Ex interface (connection box). These components are fitted onto the mounting plate and prewired. It is used for smoke monitoring in ventilation ducts with potentially explosive atmospheres.

The Duct Smoke Detector LRS 04 Ex is ATEX-approved and can be used in zones 1 and 2 (IBExU04ATEX1105, IBExU04ATEX1106).

Duct Smoke Detector LRS 04 Ex is used for incorporation of the optical smoke switch ORS 221 Ex and is mounted on the ventilation duct from the outside. The Duct Smoke Detector LRS 04 Ex is designed for application within buildings.



**Caution:**

The specifications in the explosion protection document must be observed. The ventilation ducts must be thoroughly cleaned before taking a smoke switch in ventilation systems into operation.

## 2 About this document

### 2.1 Objectives and intended readers

This document is intended to inform you about operation and installation of a electrical system in potentially explosive areas. You will find information on the following subjects:

- Safety
- Design and mode of operation
- Use of the product
- System components
- System integration
- Commissioning
- Servicing

This document is intended for the following groups of persons:

- Installation planners
- Specialist planners
- Installation technicians
- Safety officers
- Service and maintenance personnel

### 2.2 Symbols used

Some items of information in this document are specially emphasised in order to ensure quick access to such passages.



#### **Note:**

A note informs you about special features of the unit, explains important background information, or recommends a particular course of conduct.



#### **Warning of potential damage to equipment!**

This symbol is used to indicate information that is important for correct operation of the unit. Non-observance may lead to damage to the unit.



#### **Danger!**

This symbol is used to indicate information that is of importance for health and safety of persons. Non-observance may lead to damage to health and personal injury.

### 3 Safety



#### **Observe and follow the Instruction Manual!**

The Instruction Manual for operation and installation of smoke tripping device for smoke in potentially explosive areas is an integral part of the product. Before any handling, installation and start-up of units the following safety instructions, as well as descriptions and information about the present Instruction manual must be carefully read and observed.



#### **Caution - explosion hazard!**

When carrying out any work in areas in which the Duct Smoke Detector LRS 04 Ex may be installed, all necessary safety measures must be adopted to ensure that the work does not cause an explosion. Any work in hazardous areas must be authorised in writing by the responsible safety officer.



It is a fundamental rule that, when planning, installing, assembling, and operating the smoke tripping device for smoke in potentially explosive atmospheres, specific national rules and regulations must be observed. In any case, the following planning information is subordinate to specific national provisions.



The Directive 94/9/EC requires that the manufacturer and reseller ensure traceability of a product to the end user. The administration procedures for our products include a production number which is permanently marked on each product. Please note that the Duct Smoke Detector LRS 04 Ex has two production numbers:

1. One production number for the smoke switch sensor ORS 221 Ex E
2. One production number for the ORS 142 Ex interface



#### **Avoid damage to markings!**

The type plates, type designations and/or identification markings on the devices and conductor plates must not be removed, overwritten, or made illegible.

## 3.1 Guarantee claims

In case of non-compliance with the requirements/specifications contained in this Instruction Manual any claims for guarantee and liability of the manufacturer shall become invalid. Non-compliance with this clause will result in any claims for guarantee and liability against the manufacturer of the devices becoming null and void.

## 4 Project planning

The Duct Smoke Detector LRS 04 Ex is designed for application in rectangular ventilation ducts of 0.5 m to 1 m in diameter. In ventilation ducts with a round cross section, application is possible for  $\varnothing$  from 0.2 m to 1 m. The detection range to the side of the inlet tube in the channel is approx. 500 mm. The air channel base must be positioned such that reliable smoke detection can be assumed. Any interference factors that may impair safe functioning of the LRS 04 Ex must be ruled out. If required, the length of the inlet tube must be adjusted accordingly, see chapter 9 Installation.

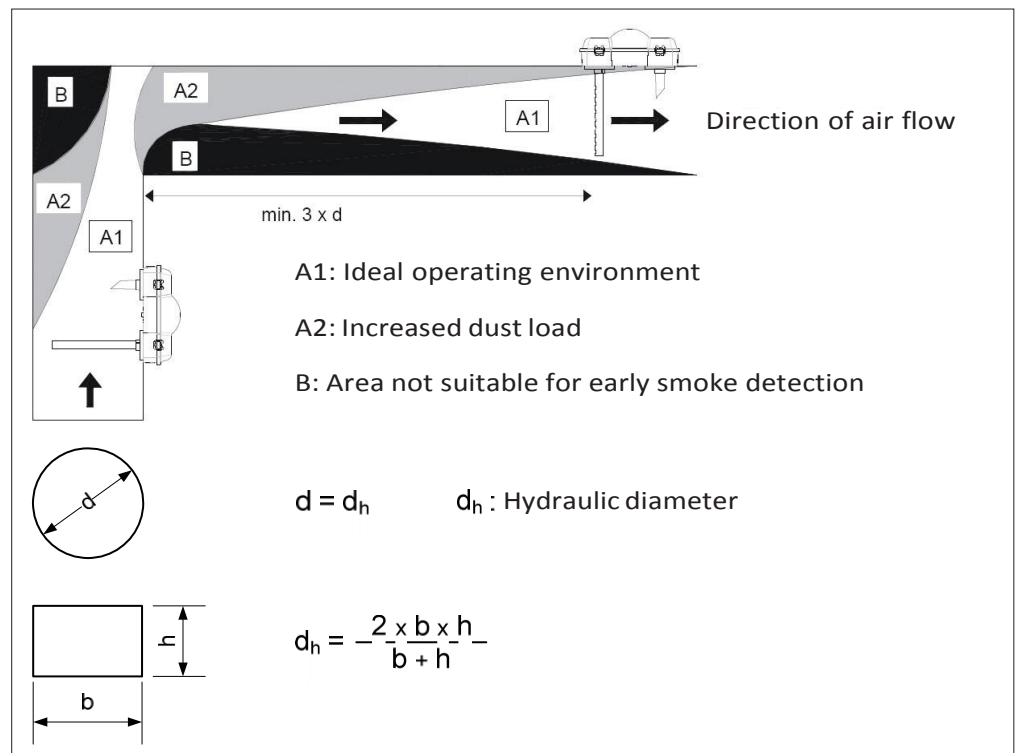
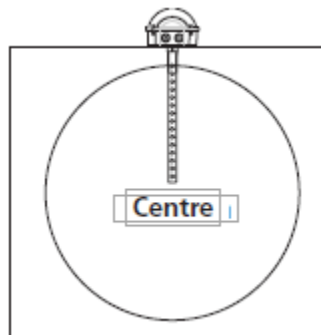

Fig.4-01

A recommendation for project planning is provided in Fig. 02.

In order to ensure reliable smoke detection in larger channels several LRS 04 Ex should be used. In doing this, the parameters of the ventilation duct with regard to monitoring of the centre of the air flow must be observed.

Fig.4-02





## 5 Technical data

### LRS 04 Ex

Field of application	Round and rectangular ventilation duct with potentially explosive atmosphere of zones 1 and 2
Functional principle	Scattered light
Smoke switch	ORS 221 Ex
Response threshold	According to the construction and testing principles for tripping devices for smoke (12/76)
Min. air flow	1 m/s
Max. air flow	20 m/s
Openings	2 x $\varnothing$ 28-30 mm/150 mm distance for installation in housing 3 x max. 6 mm or 3 pairs of openings for passing through 3 tensioning straps
Current consumption with 28 V DC	
Quiescent	Max. 12 mA
In alarm	Max. 1.8 mA
In case of a failure	Max. 2.7 mA
Relay contact in Ex interface	
Max. switching voltage	30 V DC/30 V AC
Max. switching current	1 A
Switching power max.	30 W
Inlet tube	Standard length in the channel 344 mm bore diameter $\varnothing$ 28-30 mm
Temperature range of operating environment	-20 °C to +70 °C
Degree of protection according to EN 60529	IP 54 (on duct surface)
IBExU certificate number	ORS 142 Ex interface      IBExU 04 ATEX 1105
Colour	Blue, black, white and transparent
Materials	PC/polyester/aluminium tube
Installation	On round and rectangular ventilation ducts
Cable entry	2 ATEX glands M16 x 1.5 with $\varnothing$ 4-8 mm and 1 mushroom plug
Dimensions without pipe	See dimensioned drawing (Fig. 9-01)
Weight of ventilation-duct smoke switch system (incl. inlet tube and ORS 221 Ex)	2740 g
Equipotential bonding connection	M6

## Smoke switch ORS 221 Ex

Functional principle	Scattered light	
Response threshold	According to the construction and testing principles for tripping devices for smoke (12/76)	
Degree of protection	IP 40	
Ambient temperature during operation	-20 °C to +70 °C	
Weight	120 g	
Additional output	Terminal 3 (for communication only)	
IBExU certificate number	ORS 221 Ex	IBExU04ATEX1106
Terminal cross section in ORS 142 Ex interface (connection box)	Max. 1.5 mm <sup>2</sup>	



### Note:

The ORS 221 Ex is automatically reset as soon as the sensing chamber is free of smoke. For alarm storage, the power supply unit or the connection box of the hold-open system FAD 01/FAK 01 can be equipped with a signalling and display control element SAB 04.



### Note:

The ORS142 Ex interface (connection box) is prewired with the base of the optical smoke switch ORS 221 Ex at the factory. This wiring must not be changed!

# 6 General information

## 6.1 Operation of the LRS 04 Ex

During operation, the air of the ventilation duct to be monitored permanently flows through the ventilation-duct smoke switch system LRS 04 Ex. As soon as smoke particles are detected, an alarm is triggered and the safety devices are activated. As soon as the sensing chamber is free of smoke particles again, the LRS 04 Ex is reset automatically.

## 6.2 Transport, storage and unpacking

The LRS 04 Ex is delivered packed in an appropriate fitted carton. The packaging can be recycled.

Please observe the packaging properties!

The cardboard packaging of the LRS 04 Ex fulfills the minimum packaging requirements and when stacked, has a load-bearing capacity of up to 10 times of its own weight. The packaging is only conditionally suitable for transport by post or rail. Special packaging is available for transport in tropical zones, transport by ship, etc. For more information, please contact the manufacturer.

Do not open the packaging until the unit is required for use. Retain the enclosed instructions for installation.

## 6.3 Scope of delivery

- Housing with transparent cover
- Inlet tube: Overall length 415 mm, with standard installation depth of 344 mm in the channel, prewired with earth cable
- Flow adapter ORS 221 Ex
- 2 ATEX glands M16 x 1.5, of which one is equipped with an Ex mushroom plug
- 3 LKS sealing rings
- 3 adhesive pads
- 3 self-cutting fastening screws
- 2 spring washers M6
- 2 nuts M6
- Instruction manual
- Packaging and labelling
- Optical smoke switch ORS 221 Ex

## 7 Rules and regulations

For fire protection in ventilation systems the requirements of §3 and §17 of MBO (German Model Building Regulation) apply, among others. These requirements shall be included in the building regulations of the respective country. The rules and regulations applicable in the country of use must be observed.

Extract from Model Building Regulation § 17:

"Buildings, plants and facilities must be designed such that development and spreading of fire and smoke is prevented and in case of a fire rescue of people and animals as well as efficient fire-extinguishing measures are possible."

**As a general principle, all rules and regulations must be observed in parallel in case that a product falls within the scope of application of several regulations, in order to also comply with the special requirements of every regulation.**

### 7.1 Definition of the field of application

The product LRS 04 Ex is intended for smoke detection in ventilation systems in potentially explosive atmospheres. The sensor can be installed in ventilation ducts with air flow speeds between 1 m/sec. and 20 m/sec.



Caution: The applicable rules and regulations must be observed for planning, designing, execution, application and maintenance.

For any such rules and regulations, please consider the explosion protection document or contact the explosion protection responsible.

## 7.2 Safety in potentially explosive atmospheres



Please observe the following rules for tripping devices for smoke in hazardous areas:

- The LRS 04 Ex must not be used for doors and shutters of areas in which a potentially explosive atmosphere due to combustible dust is to be assumed (zones 20 to 22).



### **Only clean with a damp cloth or sponge!**

In order to avoid electrostatic charging, only use damp cloths for cleaning purposes.

## 7.3 Intended use

The LRS 04 Ex is a tripping device for smoke for application in ventilation systems in potentially explosive atmospheres. This tripping device for smoke LRS 04 Ex is an integral part of an air-conditioning system and as such it may only be used if correctly integrated into the ventilation system. Both during commissioning and operation, the safety instructions as well as the acceptance and testing provisions of the rules and regulations to be applied for this hazardous area contained in the present Instructions Manual must be observed without failure.



### **Ensure proper use!**

- The appliance LRS 04 Ex was developed for application in potentially explosive areas classified as zone 1 or zone 2.
- The technical data stated on the equipment must be observed.
- Modifications or changes to the equipment are not permitted.
- The device must be used only for its intended purpose in an undamaged and unobjectionable condition.
- Only the ORS 221 Ex may be used as replacement smoke switch.
- A work permit must be obtained from the operator/responsible person before performing any work.

## 7.4 General safety information and protective measures

### 7.4.1 Explosion-protection regulations

In Germany, the most important points with regard to putting technical equipment on the market are covered by the *Eleventh Administrative Order to the Equipment and Product Safety Law 11. GPSGV*.

#### **Extract from § 1**

"The order shall apply for putting equipment and protective systems on the market for proper use in hazardous areas."

According to its intended use, equipment is divided into groups in accordance with Directive 94/9/EC, and assigned to equipment categories for proper use in hazardous areas.

#### **Extract from § 3**

"Equipment, protective systems, and devices [...] may not be put on the market unless they comply with the basic health and safety requirements of Directive 94/9/EC and unless they do not endanger the health and safety of persons [...] and goods, provided that they are correctly installed, maintained and properly used.

The legal requirements that govern explosion protection in the workplace are not uniform. Directive 94/9/EC determines the requirements for equipment and systems.

Directive 1999/92/EC is to be regarded as "user's directive". It specifies the types of equipment and systems that can be used and provides rules for operation and monitoring of plants with potential explosion hazards. In addition, there are various regulations that fall within the scope of the Equipment Safety Law and occupational health and safety regulations to be taken into account. Consideration must also be given to accident prevention rules, guidelines by the German employer's liability insurance association that may be issued for specific types of plants.

The following shall apply in Germany: On the basis of the body of regulations the owner/operator shall prepare or have prepared a safety concept containing a detailed hazard analysis. In this context, a specific order of principles must be taken into account.

# ATEX – Duct Smoke Detector

As a general rule, the following hierarchy of protective measures shall be observed:

1. Development of a potentially explosive atmosphere must be prevented.
  - Primary explosion protection
  - Sum of measures that prevent development and propagation of a potentially explosive atmosphere.
2. Ignition of a potentially explosive atmosphere must be prevented.
  - Secondary explosion protection
  - Sum of measures that prevent potential ignition sources from becoming effective
3. The potential impacts of an explosion must be minimised.
  - Tertiary explosion protection
  - Sum of measures that limit the impacts of an explosion to an innocuous level.

A follow-up hazard analysis should in particular address the following points:

- Determination of explosion risks to which employees might be exposed
- Selection of appropriate measures for achieving the desired level of protection
- Safe layout, operation and servicing of work equipment, warning devices and protective equipment



## **For connected areas!**

Areas that are or could be connected via openings to areas in which potentially explosive atmospheres may occur must also be taken into consideration for assessment of the explosion risks.

This procedure must particularly be complied with for tripping devices for smoke in ventilation systems.

Work carried out in ex-zones must be properly regulated and documented. A work approval system is a suitable method of regulation the organisational aspects. The employer must ensure that employees are sufficiently and appropriately instructed and trained with regard to explosion protection.

Written instructions and work approval:



**Warning of potential damage to equipment!**  
**Before starting with any work, a responsible person must issue a work approval.**

It is very important to inspect and test the systems before initial use. If required, additional measures for maintenance of explosion protection must be taken. Protective measures must be checked in regular intervals. In the event of significant changes, new measures must be adopted where appropriate.

The explosion protection document must be compiled before the start of work. It must be updated on a regular basis, particularly after changes such as:

- Extensions
- Change of the workplace layout or the work procedures
- Use of different equipment and/or tools
- etc.

Existing documents may be combined.



### 7.4.2 Classification of hazardous areas

Definition of the zones in accordance with Directive 1999/92/EC

Extract:

Hazardous areas are classified in zones on the basis of frequency and duration of the occurrence of an explosive atmosphere.

Combustible substances	Frequency and duration of occurrence of the substances	Zone classification	Identification of equipment	
			Equipment group	Equipment category
<b>Dusts</b>	Permanent, long-term or frequently present	Zone 20	II	1D
	Occasionally present	Zone 21	II	2D or 1D
	Short-term or normally not present	Zone 22	II	3D, 2D or 1D
<b>Gasses or vapours</b>	Permanent, long-term or frequently present	Zone 0	II	1G
	Occasionally present	Zone 1	II	2G or 1G
	Short-term or normally not present	Zone 2	II	3G, 2G or 1G

Notes:

Layers, deposits and accumulations of combustible dusts must be considered in the same way as is performed for every other source leading to formation of an explosive atmosphere.

The present information is intended as a summary and does not include all aspects that need to be considered. Further relevant laws, regulations and provisions applicable in the country of application must be observed as appropriate.

## 8 Product description

### 8.1 Design and mode of operation of LRS 04 Ex

The Duct Smoke Detector LRS 04 Ex is preferably used in hazard areas classified as zone 1 or 2. It detects both smoldering fires and open fires with development of smoke at a very early stage. The Duct Smoke Detector utilises the scattered-light principle. Inside the sensing chamber, a light source and a light sensor are arranged such that the light beam of the light source cannot directly fall on the light sensor. It is only when airborne particles enter the chamber that the light scattered by these particles (Tyndall effect) reaches the sensor and is converted into an electrical signal.

The figures below illustrate the structure and layout of the ventilation-duct smoke switch system LRS 04 Ex:

- ❶ Cable entry 1
- ❷ Cable entry 2
- ❸ Equipotential bonding terminal, M6
- ❹ Mounting holes  $\varnothing$  6 mm
- ❺ Opening for tensioning strap

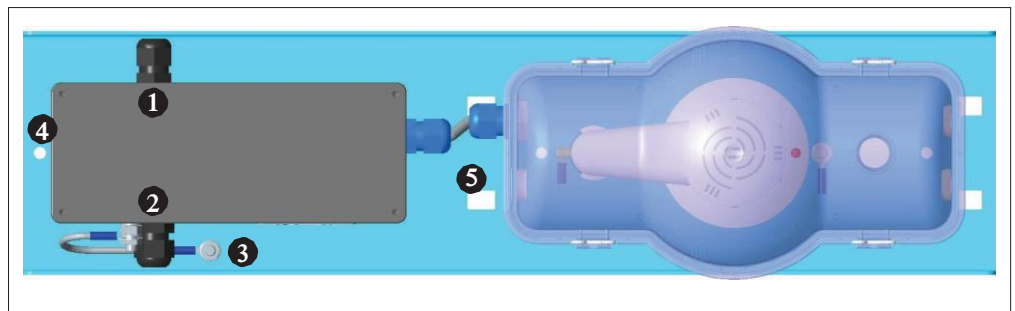

Fig. 8-01 Top view LRS 04 Ex

- ⊙ ORS 142 Ex interface (connection box)
- ❷ LKS 02
- ❸ Inlet tube
- ⊙ Outlet tube

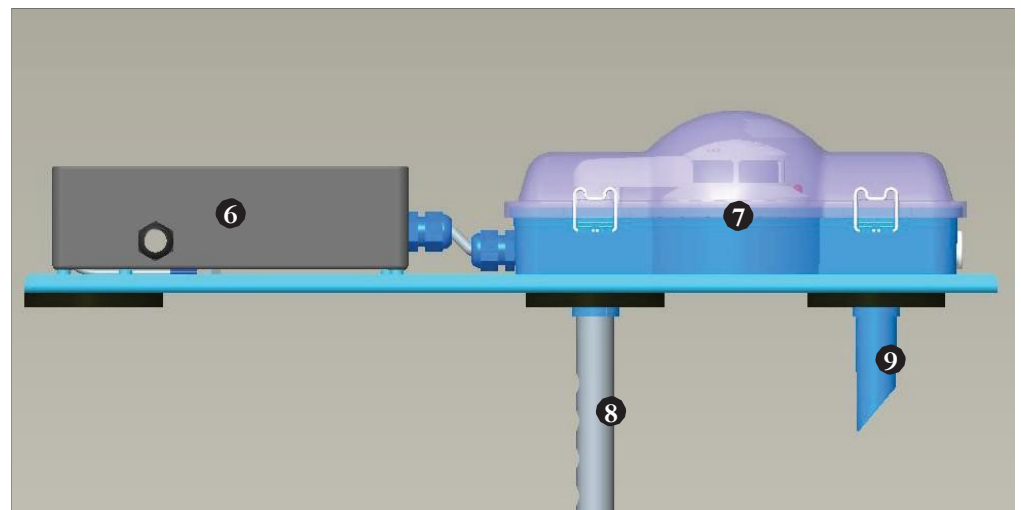

Fig. 8-02 Side view LRS 04 Ex

**Wiring of the Smoke Switch:**

Connection of the Smoke Switch must be performed in the ORS142 Ex interface (connection box) not in the smoke switch base!

## 8.1.1 Terminal assignment in the connection box of the LRS04 Ex

- ❶ In operation
- ❷ De-energised/alarm

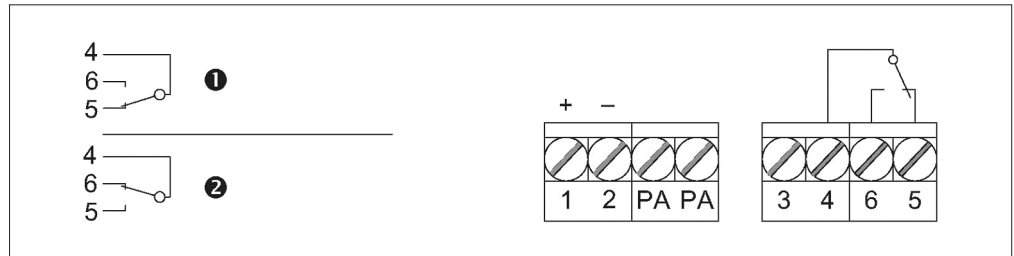

Fig.8-03 Relay contacts and connection of the LRS 04 Ex

Terminal 1	24 V DC
Terminal 2	GND
Terminal EB	Equipotential bonding (internal only)
Terminal EB	Equipotential bonding (internal only)
Terminal 3	RS bus
Terminal 4	Potential-free relay contact: Com
Terminal 5	Potential-free relay contact: NO
Terminal 6	Potential-free relay contact: NC

## 8.2 Device functions and display elements of the LRS 04 Ex

The evaluation electronics of the optical Smoke Switch ORS 221 Ex continuously monitor the smoke sensing unit of the detector and signal the following conditions by the integrated LED alarm:

Normal operation	LED flashing green (approx. every 4 seconds), relay contact is closed
Minor contamination	LED flashing in alternating colours green/yellow (approx. every 4 seconds), relay contact is closed
Heavy contamination	LED flashing twice in short succession green/yellow (approx. every 4 seconds), relay contact is opened
Failure (failure of sensing chamber)	LED flashing yellow (approx. every 4 seconds), relay contact is open
Alarm	LED flashing red (approx. once per second), relay contact is open

## 8.3 Accessories for the LRS 04 Ex

### 8.3.1 Power supply and tripping unit NAG 03

- ❶ Front view
- ❷ Side view

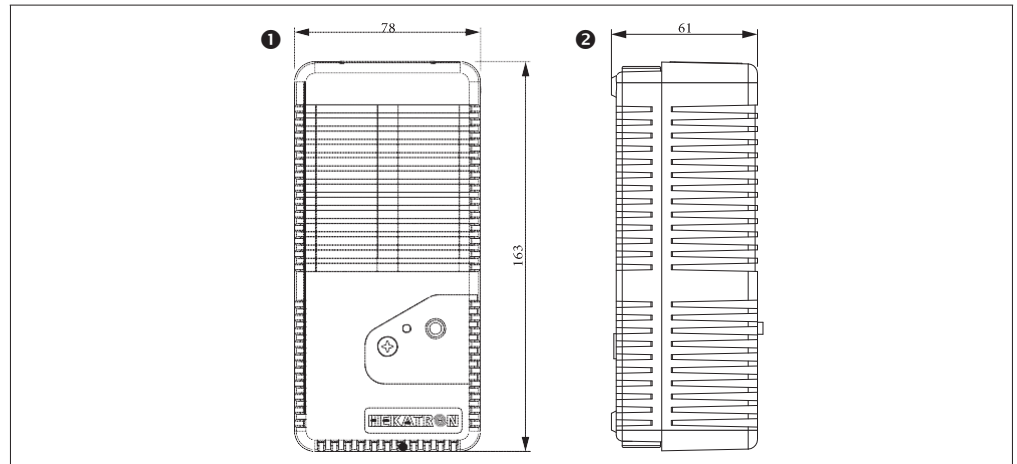

Fig.8-04 Powersupply and tripping unit NAG 03, front and side view

The power supply and tripping unit NAG 03 is primarily used for power supply of tripping devices for smoke. It contains a power supply unit and provides stabilised nominal voltage output of 24 V DC. The maximum output current is 900 mA. For additional tasks, such as transmission of an alarm, a potential-free change-over contact is freely available.



The NAG 03 is for installation in safe areas. It has protection class II. The NAG 03 does not have an inherent safety.

**Technical data**

Nominal voltage	230 V AC
Safety class	"II" (protective insulation)
Overvoltage category (acc. to DIN VDE 0110-1)	„II“
Degree of contamination (acc. to DIN VDE 0110-1)	2 (2P)
Rated frequency	50 Hz / 60 Hz
Power consumption	46 VA
Power output	21.6 W
Output voltage	24 V DC
Residual ripple U <sub>a</sub> max.	≤ 120 mV <sub>pp</sub>
Nominal current consumption	0.2 A <sub>eff.</sub>
Output current	Max. 900 mA
Relay	1 change-over contact, potential-free
Switchable voltage AC	Max. 250 V AC
Switching current AC	Max. 5 A
Switching voltage DC	Max. 30 V DC
Switching current DC with 24 V DC	Max. 5 A
Switching current DC with 30 V DC	Max. 3 A
Degree of protection	IP 30
Housing	Polycarbonate
Installation (any desired installation position, except ceiling installation)	Finery/surface-mounting
Colour	White
Cable entry	5 x max. 12 mm
Dimensions	W 78 x H 163 x D 61 mm
Ambient temperature during operation	+5 °C ... +40 °C
Part number	5400081

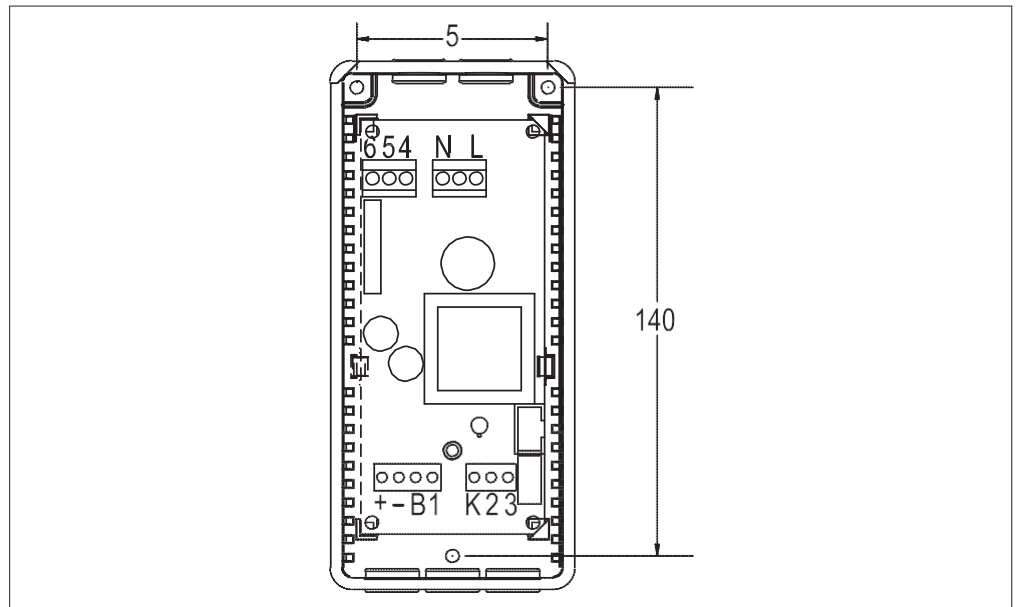

Fig.8-05 Terminals of the power supply and tripping unit NAG03

### 8.3.2 Signal and display control element SAB 04



Fig.8-06 Optional signal and display control element SAB 04, front view

The power supply and tripping unit NAG 03 can optionally be fitted (retrofitting is possible) with the signal and display control element SAB 04. After tripping of the smoke switch and after power supply failure the SAB 04 prevents automatic switch-on of the connected system components.

### 8.3.3 Manual actuation pushbutton 422 Ex

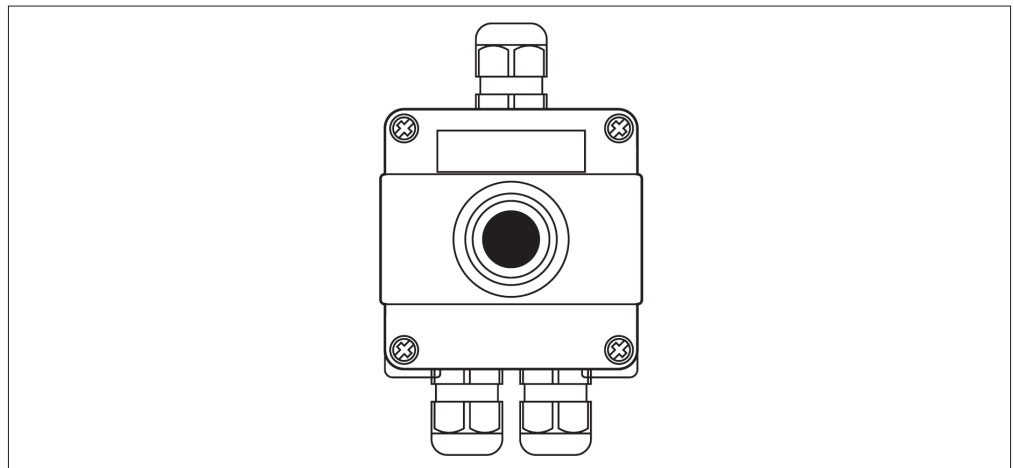

Fig.8-07 Manual actuation pushbutton 422 Ex

The manual actuation pushbutton 422 Ex is used for manual actuation of fire and smoke protection flaps and control of ventilation systems in potentially explosive environments. It is suitable for application in areas with a Zone 1 and Zone 2 explosion hazard and in areas for which *degree of protection IP 65* is required. The manual actuation pushbutton 422 Ex has ATEX approval.

The manual actuation pushbutton 422 Ex is intended for surface installation. It is also suitable for application in moist rooms.



**Technical data**

Type of contact	NC
Switching voltage	13 V DC ... 24 V DC
Switching current	Max. 1 A
Ambient temperature during operation	-50 °C ... +60 °C
Degree of protection	IP 65
Cable entry	M20 x 1.5
Cable diameters	5 mm ... 9 mm
PTB No.	PTB 00 ATEX 1068
Type of explosion protection	⊕ II 2 G EEx edm IIC T6
Housing	Plastic
Dimensions without cable glands	W 88.5 x H 91 x D 91

**8.3.4 Connection box Ex**

Fig.8-08 Connection box Ex

The Ex-connection box is suitable for application in areas with a Zone 1 and Zone 2 explosion hazard and in areas for which degree of protection IP 65 is required. The Ex-connection box is the preferred method to ensure safe connection of lines within a potentially explosive area.

The Ex-connection box is a polyester housing, protection type *Increased Safety „e“*, with openings for cables and lines. The branching and connection box contains cable glands and terminals of protection type *Increased Safety „e“*.

For protection of Ex-terminals from mechanical damage, contact, dust and humidity, the terminal must be installed in housings with *Increased Safety „e“* classification.

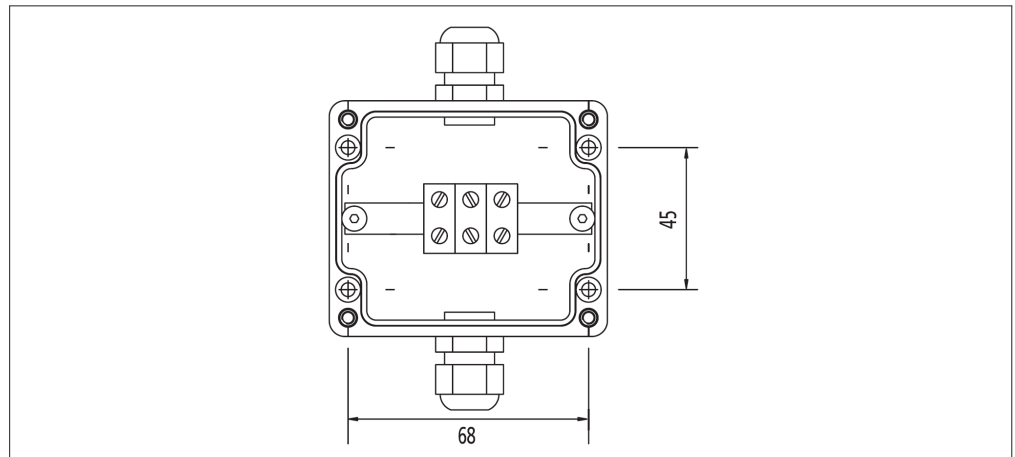
For branch connections 2- and 3-pole insert bridges are available. Depending on the selected diameter, wire end ferruled must be used where appropriated.

Unused conductors must be fixed.

## Technical data

Ex connection box (type 07-5103)	II 2 G EEx e II T6
EC prototype test certificate number	PTB 01 ATEX 1104

### 8.3.5 Smoke switch condition indicator RZA 142



Fig. 8-09 RZA 142, front view

The smoke switch status indication RZA 142 receives signals for and displays the following statuses via the communication interface Pin 3 of the LRS 04 Ex: operation, slight contamination, heavy contamination, fault or alarm. In addition to the visual indication, a potential-free change-over contact is assigned to every status; the contacts are used to transmit statuses to higher-order systems, (such as a central building control system).



The RZA 142 is exclusively intended for installation in safe areas. The RZA 142 does not have inherent safety.

If an RZA 142 is used in parallel to the LRS 04 Ex, the ORS 221 Ex must be re-initialised after installation of after replacement in connection with this RZA 142.

## 9 Installation directions

### 9.1 Mechanical installation of the LRS 04 Ex

#### Brief overview of procedures:

1. Select the place of installation according to project design specifications (planning concept, explosion protection document, etc.)
2. Open the housing cover at the LRS
3. Mount LRS 04 Ex to the channel
4. Clean the ventilation channel and the inlet tube
5. Screw the ORS 221 Ex into the base
6. Perform wiring with auxiliary components and connect ORS 142 Ex interface (connection box)
7. Check using test aerosol 918/5
8. Insert inlet tube into the LRS 04 Ex
9. Place the equipotential bonding of the inlet tube once around the base (see Fig. 9-02).
10. Connect the equipotential bonding of the inlet tube with the equipotential bonding M6 in the LRS 04 Ex using the supplied spring washer and the M6 hex nut.
11. Close the cover of the LRS 04 Ex



#### Caution:

The smoke switch LRS 04 Ex must be used together with the supplied inlet tube. The tube must not be bent!

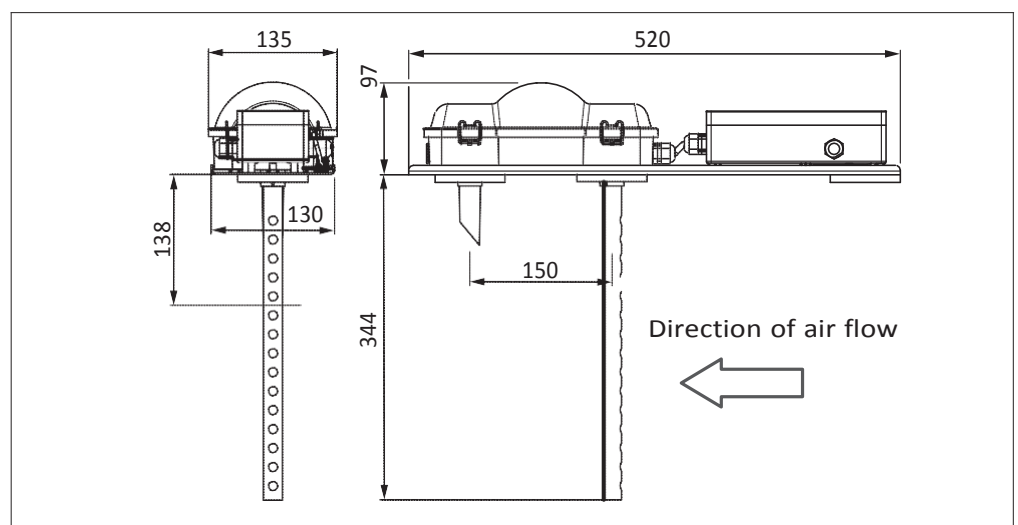

Fig.9-01

When determining the place of installation of the LRS 04 Ex, it must be ensured that it is possible for the inlet tube to be replaced at the place of installation. For removal of the inlet tube a clearance of minimum 470 mm must be provided. During installation of the LRS 04 Ex, mounting must be with as little vibration as possible. The tube must not be bent. It must be ensured that the direction of installation of the LRS 04 Ex is corresponding to the air flow direction in the channel. For that purpose, the LRS 04 Ex must be mounted such that the arrows (marked on the bottom of the housing) see Fig. 9-02 point into the direction of the air flow within the channel.

The LRS 04 Ex is directly mounted onto the channel axially to the direction of air flow using appropriate fastening elements and it is then sealed by means of the LKS sealing rings with adhesive pad. Fastening can be performed by means of the supplied, self-cutting screws or by means of tensioning straps. The three additional LKS sealing rings with adhesive pad are intended for smaller round channel for additional sealing.

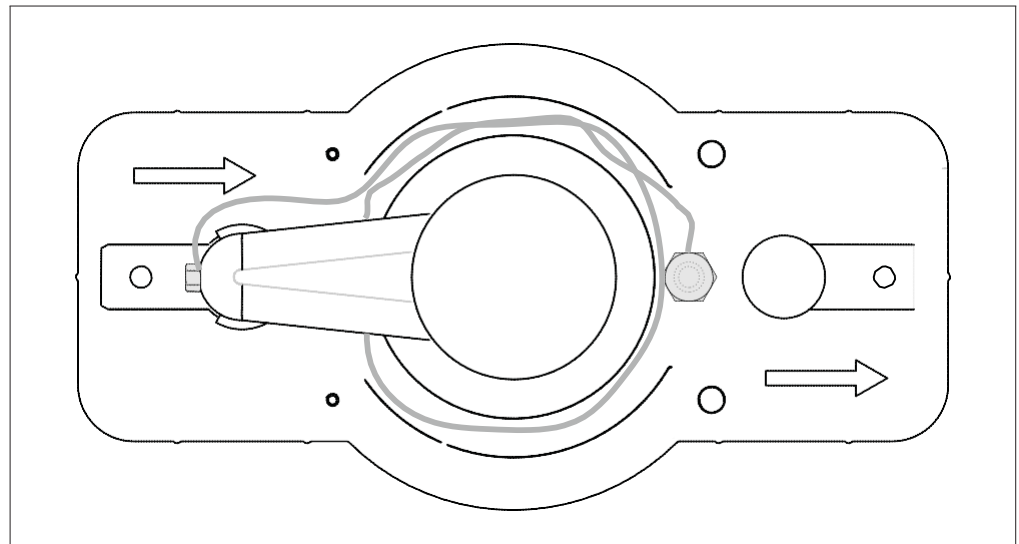

Fig.9-02



**Caution:**

When mounting the LRS 04 Ex, the direction of air flow must be observed and tightness must be ensured.

In case the supplied self-cutting screws (4.8 x 22) are not suitable for fastening the unit at the ventilation duct, appropriate fastening materials, such as tensioning straps must be used. The LRS 04 Ex is equipped with three 6 mm holes (see figure) and three pairs of openings for tensioning straps.

Two large openings for the inlet tube and - the outlet tube are cut into the ventilation duct (see Fig. 9-03).

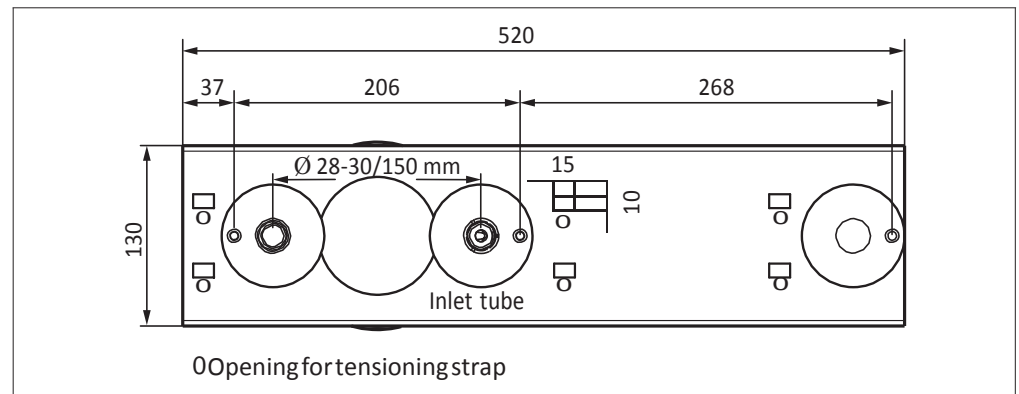

Fig.9-03 Hole dimensions

### Opening the cover the LRS 04 Ex

The LRS 04 Ex is equipped with quick fasteners for service purposes. These must only be opened if an approval for working in hazardous areas has been granted. Closing and opening of the clips can be facilitated by slightly pressing down the housing cover by hand. In case of overhead assembly of the LRS 04 Ex it must be ensured that no parts or elements (transparent cover, intake pipe, etc.) are dropped on the floor when opening the transparent cover.

### Handling

The inherently safe wiring with the ORS 221 Ex is executed in the factory and must not be modified. The ex-protected dummy plugs must be left in the cable glands.

After positive functional testing by means of test aerosol 918/5 the inlet tube with the flow adapter can be inserted. The equipotential bonding connection pre-installed at the inlet tube must also be left unchanged. Subsequently, the cover of the ventilation-duct smoke switch system LRS 04 Ex can be re-installed by slightly pressing it on and closing the clips.

### Limits of application

In case of interference factors arising due to operating conditions, such as, dust, smoke, humidity or steam, false alarms due to sensor deception are possible. It must be ensured that the smoke switch is not exposed to condensation. The LRS 04 Ex is not designed for outdoor applications. This information must be taken into consideration when planning and designing the system.

## 9.2 Electrical connection



### Safety notes:

When introducing and fastening the cables it must be ensured that no leakages occur towards the ventilation duct. In LRS 04 Ex the LED of the ORS 221 Ex or the arrow in the base points towards the outlet tube. Correct functioning of the LRS 04 Ex is only ensured with the cover properly closed.

For introduction of cables the unit is equipped with cable glands, 2xM16, according to ATEX. With proper use, IP 54 is complied with for the sealing area of 4 - 8 mm.

Equipotential bonding must be connected to the M6 bolt on the mounting plate as intended. The spring washers and hex nuts required, are supplied with the unit. The required cross section of the line and the properties of the cable jacket must be adapted to the conditions present.

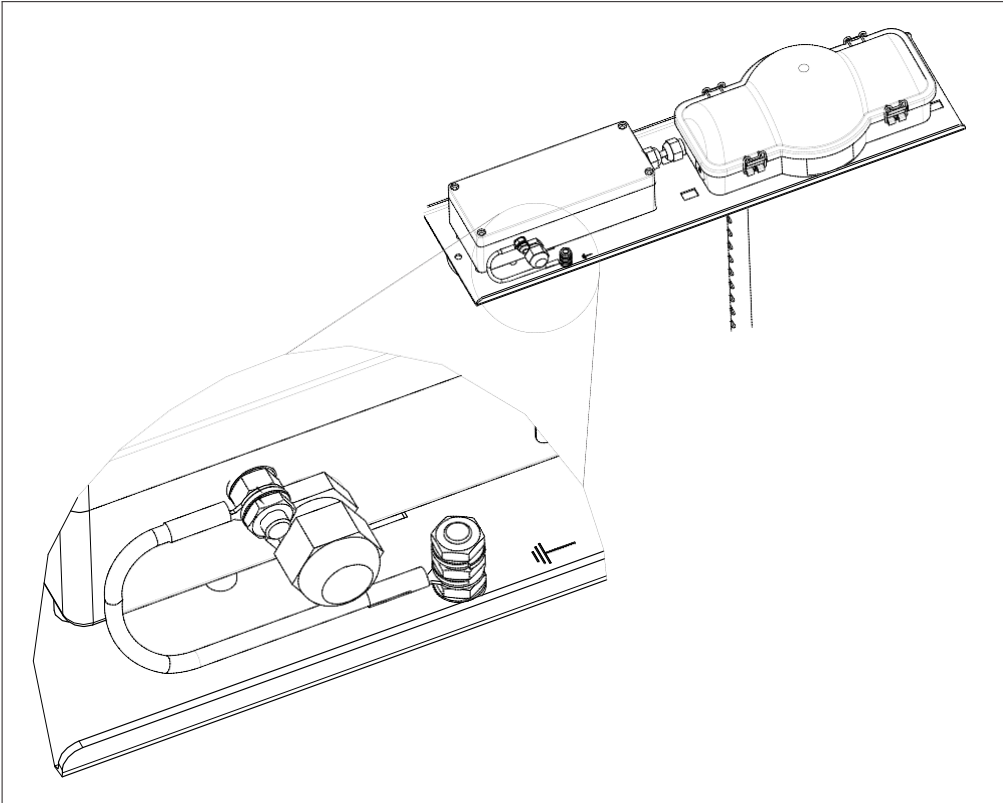
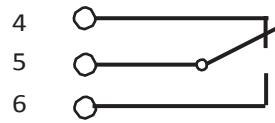

Fig.9-04 Equipotential bonding

## Switching position of the relay contact in ORS 142 Ex interface

---



- Operation
- Minor contamination

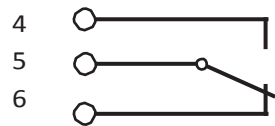

- Heavy contamination
  - De-energised
  - Fault
  - Alarm
- 

### Electrical installation

The electrical installation must be carried out in compliance with all valid rules and regulations. Equipotential bonding via the provided connection must be made with minimum 4 mm<sup>2</sup>.



## Cable installation

For the low voltages any conventional communication cables with or without shielding may be used. The diameter of the conductor must be selected in accordance with the current consumption of the used devices and in compliance with the length of conductors.

- Cable diameters max. 9 mm
- Recommended conductor type IY(ST)Y 4 x 2 x 0.8 mm
- Only conductors with the same cross section may be wired to the same terminal.
- The conductors must be installed such that sufficient traction relief is ensured.
- The cables must be selected together with the owner/operator on the basis of their required properties suitable for ex-atmosphere requirements.

## Load capacities of contacts



### Caution:

The electrical limit values for load capacity of the relay contacts (30 V DC/1 A or 30 V AC/1 A) must not be exceeded, not even for short periods. Consequently, suitable measures for protection of the contacts must be taken.



### Safety notes:

Safety-relevant shut-down / control of the system must be performed via the relay contact of the ORS 142 Ex interface, terminals 4 and 5. The operation and information statuses that are transmitted e.g. to the smoke switch status indication RZA 142 via communication interface (terminal 3) and are used for comfortable display / information and transmission to the central building control system GLT.

## 9.3 Switching examples

For control/activation of fire and smoke protection flaps the NAG 03 should be applied.

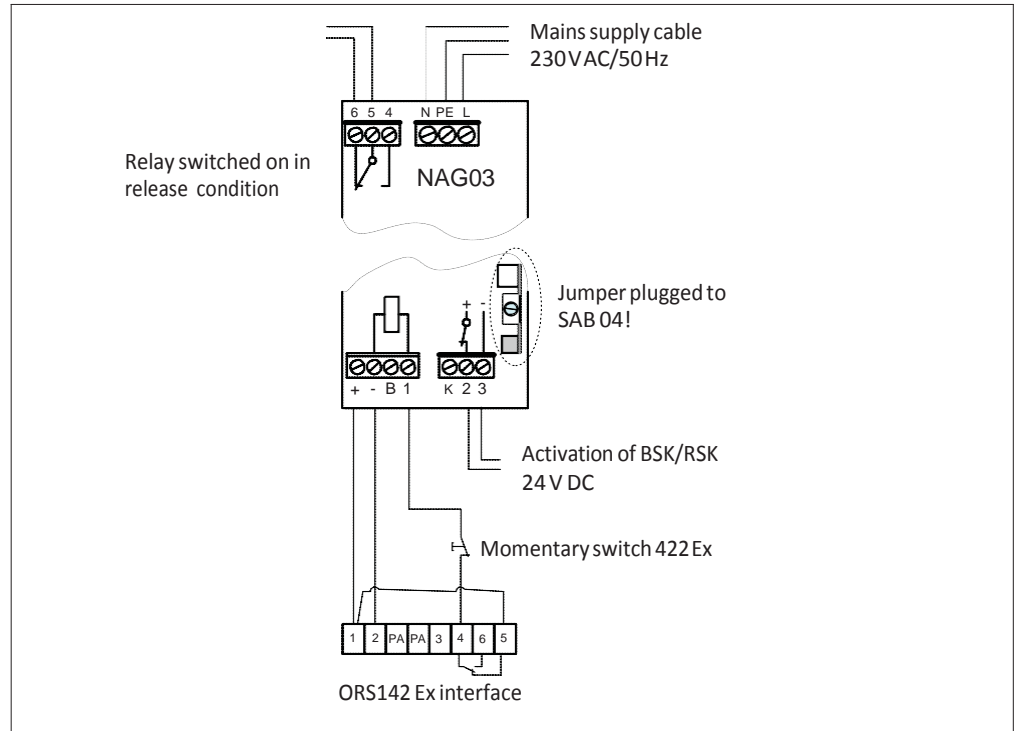

Fig.9-04 Activation of a 24V DC BSK/RSK

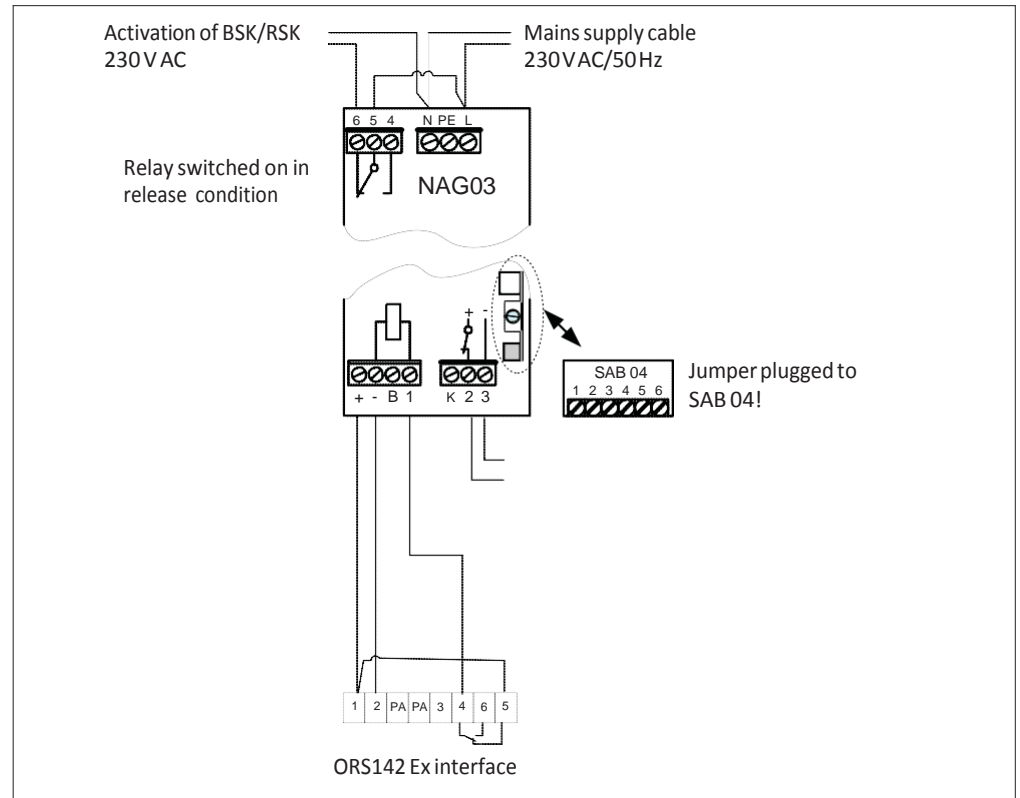

Fig.9-05 Activation of a 230VACBSK/RSK

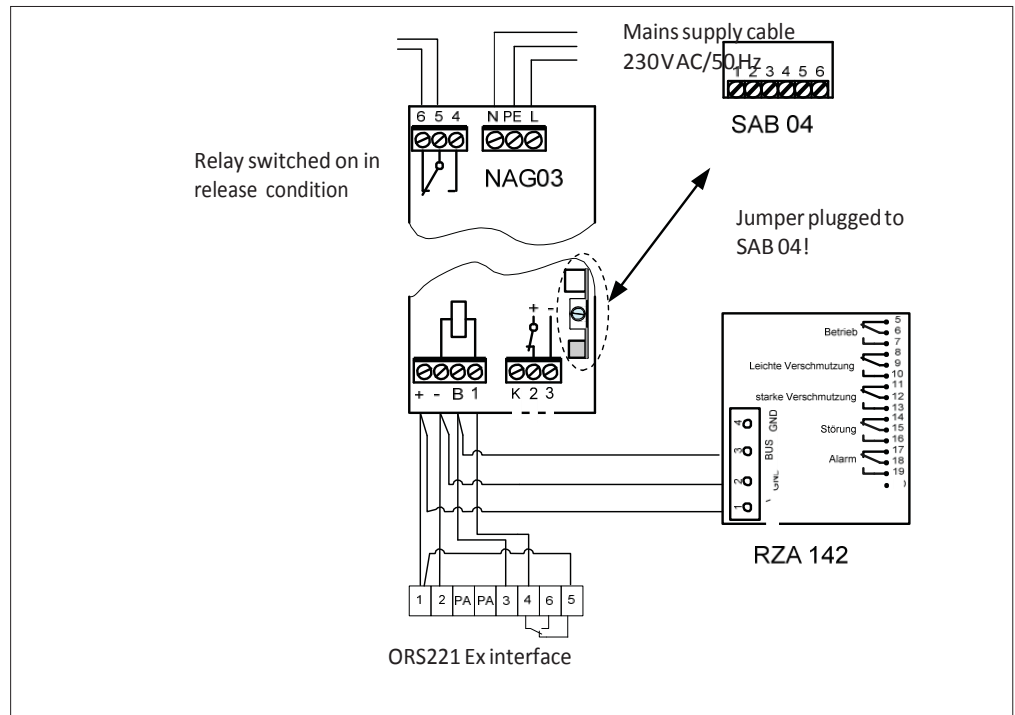

Fig.9-06 LRS 04 Ex with mains and tripping device NAG 03 with RZA 142

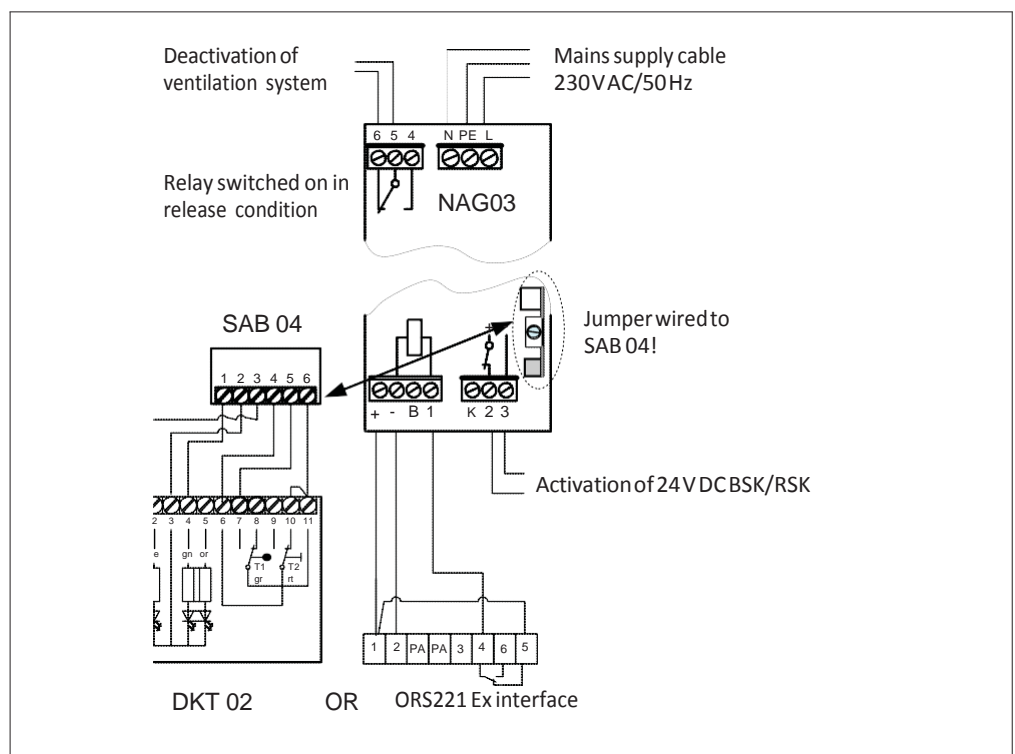

Fig.9-07 Activation of a 24V DC BSK/RSK with deactivation of ventilation system with additional DKT 02

## 10 Commissioning



### Caution:

The ventilation ducts and the LRS 04 Ex must be thoroughly cleaned before taking a smoke switches in ventilation systems into operation. The smoke switches ORS 221 Ex should only be taken out of their packaging and inserted into the base of the LRS 04 Ex after cleaning is completed.

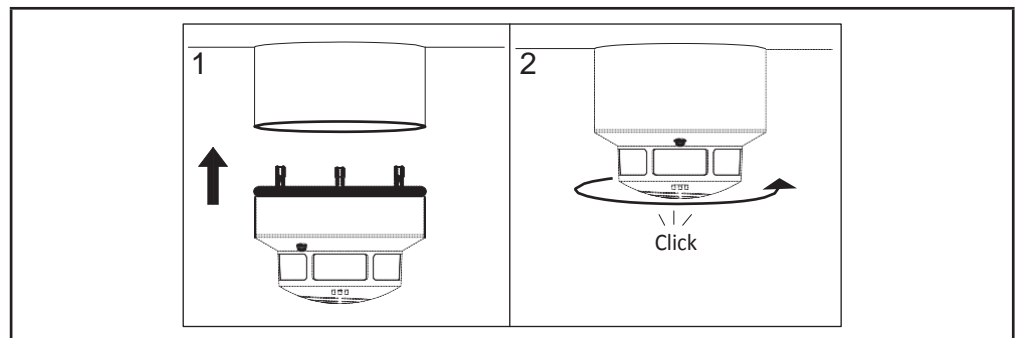

Fig.10-01: Insertion and screwing-in of the smoke switch ORS221 Ex

### 10.1 Functional testing

Inspection must at least include the following aspects:

Interaction of all devices and their correct technical condition must be verified.

The fire protection flap / smoke protection flap and/or the ventilator must switch into safety position "closed and/or off" and remain in that position, if

- Smoke is detected
- A fault occurs at the smoke switch  
(e.g. due to removal of the smoke switch from the base)
- The energy supply fails/returns
- The manual actuation pushbutton is pressed

For testing of smoke detection the test aerosol 918/5 should be used. The test aerosol is free from halogenated hydrocarbons (CFC and the like). If a smoke switch does not react to, i.e. is not triggered by this test, it must be replaced. The inlet openings at the inlet tube of the LRS 04 Ex must be kept unblocked.

## 10.2 Servicing

### 8 steps for easy maintenance:

1. Have the area released for work



#### Safety notes:

Any work in hazardous areas must be authorised in writing by the responsible safety officer.

2. Open housing cover by the fastening clips
3. Remove tube, inspect visually and clean if required
4. Wipe the smoke switch with a damp cloth



#### Safety notes:

In order to avoid electrostatic charging, only use damp cloths for cleaning purposes.

5. Spray test aerosol 918/5 onto the smoke switch
7. Insert tube
8. Close housing cover by the fastening clips

The described tests and maintenance must only be carried out by an expert of a specially qualified person. **The tests and the respective results must be recorded in a test log, e.g. IW-Set BSK/RSK by AP.**



#### Caution:

ORS 221 Ex and ORS 142 Ex are not compatible.



#### Do not use aggressive cleaning agents

Aggressive cleaning agents such as solvents, benzene or other alcohol-containing substances as well as cleaning agents containing chemical additives must not be used for cleaning.



#### Caution:

The warning and safety information printed on the test aerosol cylinder must always be observed!

### 10.3 Display of operating statuses of the ORS 221 Ex

Condition	Display	Relay contact
Normal operation	LED flashing green (approx. every 4 seconds)	Relay contact is closed
Minor contamination	LED flashing in alternating colours green/yellow (approx. every 4 seconds)	Relay contact is closed
Heavy contamination	LED flashing twice in short succession, in alternating colours green/yellow (approx. every 4 seconds)	Relay contact is open
Failure (failure of sensing chamber)	LED flashing yellow (approx. every 4 seconds), relay contact is open	Relay contact is open
Alarm	LED flashing red (approx. once per second)	Relay contact is open

# 11 Provisions for maintenance and servicing

The rules and regulations for hazard areas and the provisions of the BG Chemie must be complied with.

The LRS 04 Ex system should be kept operational at all times and be serviced at least once per year according to manufacturer information in compliance with the basic principles for maintenance and according to the rules and regulations applicable for the specific hazard area in accordance with DIN 31051 in connection with DIN EN 13306.

In consideration of the special conditions of the operation environment, the AP Duct Smoke Detector must be subjected to servicing and maintenance according to VDE 0833 Part 1.

We recommend to subject the Duct Smoke Detector to a work revision procedure after an operation period of 8 years. Work revision may be required at an earlier stage due to special conditions present in the operation environment: e.g. excessive strain, severe external influences, contamination, etc.

**Caution:**

Before any maintenance work, a work approval must be obtained and the hazard area must be de-energised.

For function testing of the smoke switch ORS 221 Ex the test aerosol 918/5 by AP should be used.

**Caution:**

Interaction of all devices and their correct functioning must be verified.

**Caution:**

The inlet tube is to be checked during regular visual inspection. For visual inspection, remove the inlet tube from the LRS 04 Ex and remove any present residue. After visual inspection and possibly cleaning, re-insert the inlet tube correctly.

**Safety notes:**

The smoke switch ORS 221 Ex must not be opened!



## 12 Ordering data

<b>Designation</b>	<b>Order no.</b>
LRS 04 Ex	31-5000006-01-01
Spare smoke switch ORS 221 Ex	31-5000005-01-01
Spare base 143 A	5000350
Signal and display control element SAB 04	4400043
Ex connection box (Type 07-5103)	6900360
LKS inlet tube Ex	31-4100005-01-01
Power supply unit NAG 03	5400081
Power supply unit NAG 03 with SAB 04	5400084.0201
Power supply unit NAG 04	6100013
Connection box for hold-open device FAD 01	5700103
Connection card for hold-open device FAK 01	6300116
Test Aersol 918/5	6900331
IW Set BSK/RSK	7001996



**Caution:** Depending on the printer settings in your PC the dimensions of the drilling template may be distorted. Please deactivate the setting "adjust to page margins" when printing. To be on the safe side, verify that the dimensions of the template are correct before drilling the holes.

