

K-SML05/10/15 Motor Driven Sirens

The E2S range of motor driven sirens offer the traditional “air raid” type warning signal designed to give effective warning over wide areas. The powerful low frequency sound is ideal for covering long distances and is instantly recognisable.

The simple, rugged design is low maintenance and offers the lowest cost solution to disaster warning applications such as COMAH (SEVESO II) toxic gas alarms, flood and tsunami warning, security alert, civil defence, tornado and bad weather alert. Using the matching control panel, these sirens can produce up to 3 distinct warning tones and there are a variety of control options to suit customer requirements. Controls can be linked by hard wire, telephone cables or radio control using digital telemetry to create a secure communication network.

E2S has considerable experience in this field and is able to offer full pre and post installation support including assistance with siren selection.

K-SML05 features:

A robust, rugged cast aluminium siren with a very powerful low frequency output. Ideally suited for use in factories, refineries, quarries, construction and industrial sites, as well as both underground and surface mining.

- Maximum Output: 135 db (A) @ 1m
- Tones: Continuous or Wail Tone (when supply is switched on/off)
- Frequency: 560Hz
- 1 Km effective range
- Voltages: 400v 3 Phase
- Motor Power: 2.2kW
- Duty: Continuous
- Enclosure Material: Cast Aluminium
- Colour: Grey, other colours available
- Operating Temperature: -20 to +40°C
- Storage Temperature: -40 to +70°C
- Relative Humidity: 90% at 20°C
- Weight: 50Kg

K-SML10 features:

Precision machined aluminium body with all weather enclosed, continuously rated motor. Ideally suited for use in factories, refineries, quarries, construction civil defence and industrial sites, as well as both underground and surface mining.

- Maximum Output: 140 db (A) @ 1m
- Tones: Continuous or Wail Tone (when supply is switched on/off)
- Frequency: 560Hz
- 1.5Km effective range
- Voltages: 400V 3 Phase
- Motor Power: 4kW
- Duty: Continuous
- Enclosure Material: Cast Aluminium
- Colour: Grey, other colours available
- Operating Temperature: -20 to +40°C
- Storage Temperature: -40 to +70°C
- Relative Humidity: 90% at 20°C
- Weight: 68Kg

K-SML15 features:

All weather enclosed motor is ideally suited for outdoor use. This siren would be used for audible warning at refineries, oil rigs, in the event of fires and open-cast mining operations. This precision machined unit produces a powerful dual low frequency sound that is ideal for long distance signalling.

- Maximum Output: 145 db (A) @ 1m
- Tones: Continuous or Wail Tone (when supply is switched on/off)
- Frequency: 560Hz
- 2.5Km effective range
- Voltages: 400V 3 Phase
- Motor Power: 7.5kW
- Duty: Continuous
- Enclosure Material: Cast Aluminium
- Colour: Grey, other colours available
- Operating Temperature: -20 to +40°C
- Storage Temperature: -40 to +70°C
- Relative Humidity: 90% at 20°C
- Weight: 118Kg



K-SML15



K-SML05



K-SML10

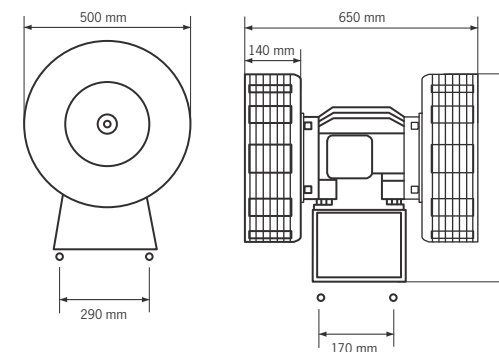
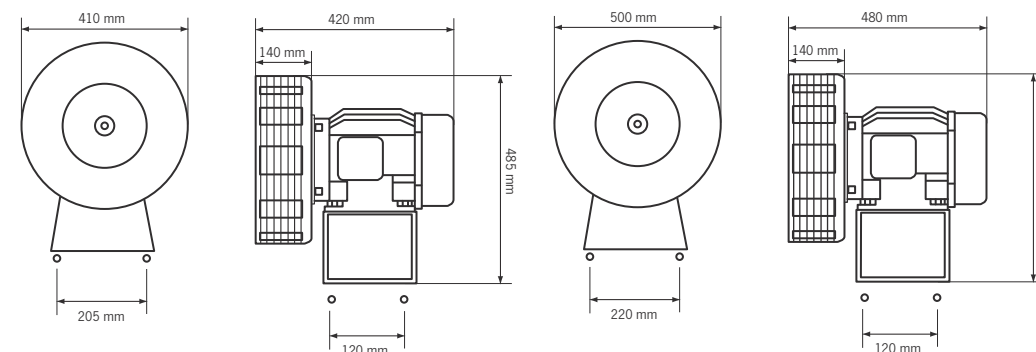

Part codes:

Version:	Part code:	SPL:
K-SML05 380V ac	K-SML05AC380G	135dB(A) @ 1m
K-SML10 380V ac	K-SML10AC380G	140dB(A) @ 1m
K-SML15 380V ac	K-SML15AC380G	145dB(A) @ 1m

Other voltages available on request.