

# INSTRUCTION MANUAL

## (ATEX / IECEx / UKEX / DNV GL)

### STExCP8-PB-S, STExCP8-PB-D, STExCP8-PM-S, STExCP8-PM-D, STExCP8-PT-S & STExCP8-PT-D CALL POINTS

**For use in Flammable Gas Atmospheres and Marine Environments**

**STExCP8-PB**

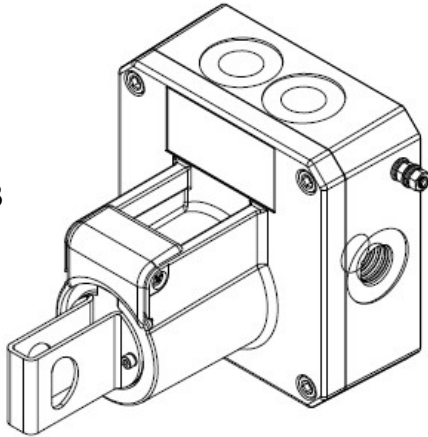

**STExCP8-PM**

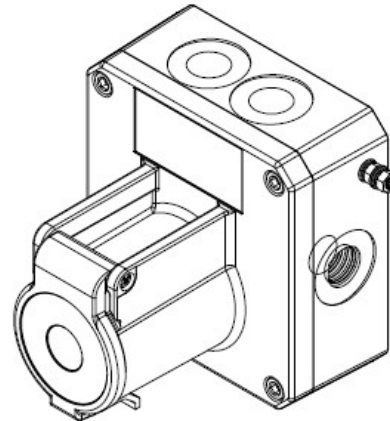

**STExCP8-PT**

### 1) Warnings



- USE COVER BOLTS CLASS A4-70
- DO NOT OPEN WHEN AN EXPLOSIVE ATMOSPHERE IS PRESENT
- POTENTIAL ELECTROSTATIC HAZARD
- ALL ENTRIES M20 X 1.5
- DO NOT OPEN WHEN ENERGIZED
- IF TEMPERATURE EXCEEDS 70°C AT ENTRY OR 80°C AT BRANCHING POINT USE SUITABLE RATED CABLE AND CABLE GLANDS

ATEX Marking  
Equipment Group and  
Category:

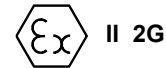

CE Marking  
Notified Body No.



UKCA Marking  
Notified Body No.



The units can be installed in locations with the following conditions:

#### Area Classification Gas:

Zone 1	Explosive gas air mixture likely to occur in normal operation.
Zone 2	Explosive gas atmosphere not likely to occur in normal operation but may be present for short periods.

#### Gas Groupings:

Group IIA	Propane
Group IIB	Ethylene
Group IIC	Hydrogen and Acetylene

#### Temperature Classification:

T1	450°C
T2	300°C
T3	200°C
T4	135°C
T5	100°C
T6	85°C (For Dual Switch models only up to Tamb 60°C)

**IP Rating:** IP66/67 to EN/IEC60529 and IP6X to EN/IEC60079-0, EN/IEC60079-31

**Equipment Category:** 2G

**Equipment Protection Level:** Gb

**Ambient Temperature Range:**  
-55°C to +70°C Gas Groups IIA, IIB and IIC

### 2) Rating & Marking Information

#### 2.1 ATEX / IECEx / UKEX Certification

All units have a rating label, which carries the following important information:-

**Model No.:** STExCP8-PB-S (Single Switch)  
STExCP8-PB-D (Dual Switch)

STExCP8-PM-S (Single Switch)  
STExCP8-PM-D (Dual Switch)

STExCP8-PT-S (Single Switch)  
STExCP8-PT-D (Dual Switch)

**Input Voltage:** DC Units 48Vdc Max  
AC Units 250Vac max (units without series or end-of-line devices only)

**STExCP8-PB-S ; -PM-S ; -PT-S Codes:**  
Ex db IIC T6 Gb Ta. -55°C to +70°C

**STExCP8- PB-D ; -PM-D ; -PT-D Codes:**  
Ex db IIC T5 Gb Ta. -55°C to +70°C  
Ex db IIC T6 Gb Ta. -55°C to +60°C

**Certificate No.** DEMKO 15 ATEX 1589X  
IECEX ULD 15.0018X  
UL21UKEX2133X

## 2.2 DNV GL Type Approval

The units have been tested and approved for the installation on ships in the following locations:

<b>Temperature:</b>	Class A,B,C & D (all locations including open decks and masts)
<b>Humidity:</b>	Class A & B (all locations)
<b>Vibration:</b>	Class A (all locations except installation on machinery such as combustion engines, compressors, pumps, including piping on such machinery)
<b>EMC:</b>	Class A & B (all locations including open decks and bridge)
<b>Enclosure:</b>	Class A, B & C – IP56 (all locations except submerged applications and bilges)

## 3) Type Approval Standards

The beacon carries an EC Type Examination Certificate and IECEx Certificate of Conformity, and have been certified to comply with the following standards:

EN60079-0:2012+A11:2013 / IEC60079-0:2011 (Ed 6):  
Explosive Atmospheres - Equipment. General requirements

EN60079-1:2014 / IEC60079-1:2014 (Ed 7):  
Explosive Atmospheres - Equipment protection by flameproof enclosures "d"

## 4) Installation Requirements

The beacon must only be installed by suitably qualified personnel in accordance with the latest issues of the relevant standards:

EN60079-14 / IEC60079-14: Explosive atmospheres - Electrical installations design, selection and erection

EN60079-10-1 / IEC60079-10-1: Explosive atmospheres - Classification of areas. Explosive gas atmospheres

The installation of the beacon must also be in accordance with any local codes that may apply and should only be carried out by a competent electrical engineer who has the necessary training.

The equipment must not be installed with any obstruction to the flanged flameproof joint any closer than permitted as per EN/IEC60079-14, table 13.

## 5) Special Conditions of Use

On completion of the installation the flameproof joint surfaces should be inspected to ensure that they are clean and that they have not been damaged during installation. Flameproof joints are not permitted to be repaired.

When fitting the flameproof cover ensure the cover is sitting flat and correctly positioned on the base. Insert the M6 x 40 cover bolts and fully tighten down (tightening torque 8.8Nm), ensuring no gap is visible between the cover and base of the enclosure.

The metallic enclosure has a non-conductive coating. These may generate an ignition-capable level of electrostatic charges under certain extreme conditions. The user should

ensure that the equipment is not installed in a location where it may be subjected to external conditions that might cause a build-up of electrostatic charges on non-conducting surfaces.

Additionally, cleaning of the equipment should be done only with a damp cloth.

The M12 Cap fitted to the top side of the unit is not a user serviceable part and must not be removed during installation and maintenance.

## 6) Location and Mounting

The location of the call point should enable ease of access for operation and testing. The unit should be mounted using the 4 off fixing holes which will accept up to M5 sized fixings. They should only be fixed to services that can carry the weight of the unit.

To gain access to the mounting holes in the base the front cover must be removed. See Section 7.

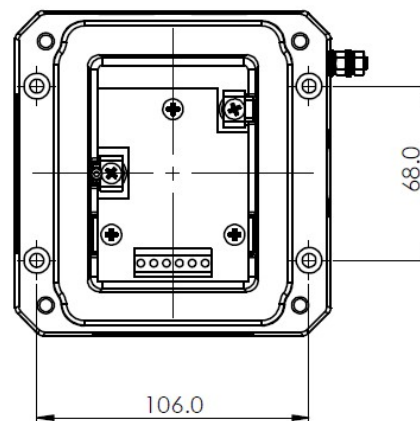

Fig. 1 View of base unit showing fixing centres (in mm).

## 7) Access to the Flameproof Enclosure



Warning – High voltage may be present, risk of electric shock. DO NOT open when energised, disconnect power before opening.



Warning – Hot surfaces. External surfaces and internal components may be hot after operation, take care when handling the equipment.

To access the Ex d chamber, remove the four off M6 x 25 hexagon socket head screws and withdraw the flameproof cover taking extreme care not to damage the flameproof joints in the process. M6 cover screws are Class A4-70 stainless steel and only screws of this category can be used for the enclosure.

On completion of the installation, the flameproof joints should be inspected to ensure that they are clean and that they have not been damaged during installation.

Once the screws are removed the cover will hang down out of the way to gain access to the terminals, the internal earth terminal and mounting hole recesses.

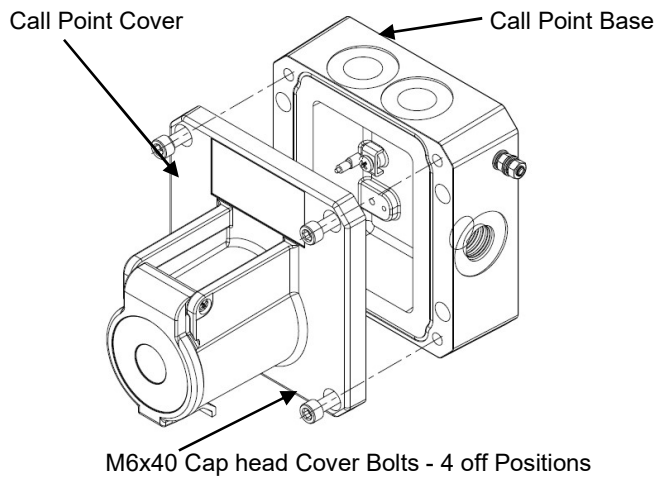

Fig. 2 Accessing the Explosion proof Enclosure.

Check that the earth bonding wire between the two castings is secure and the 'O' ring seal is in place. When replacing the flameproof cover casting ensure that it is square with the flameproof chamber casting before inserting. Carefully place the cover on the base. Only after the cover is fully in place should the four M6 Stainless Steel A4-70 cover bolts and their spring washer be tightened down. Never use the cover bolts to force the cover into position.

## 8) Earthing

The units are provided with internal and external earth terminals which are mounted in the base of the unit.

Internal earthing connections should be made to the Internal Earth terminal in the base of the housing using a ring crimp terminal to secure the earth conductor under the earth clamp. The earth conductor should be at least equal in size and rating to the incoming power conductors.

When using the internal earth terminal ensure that the stainless steel M4 flat washer is between the incoming earth wire and the enclosure.

External earthing connections should be made to the M5 earth stud, using a ring crimp terminal to secure the earth conductor to the earth stud. The external earth conductor should be at least 4mm<sup>2</sup> in size.

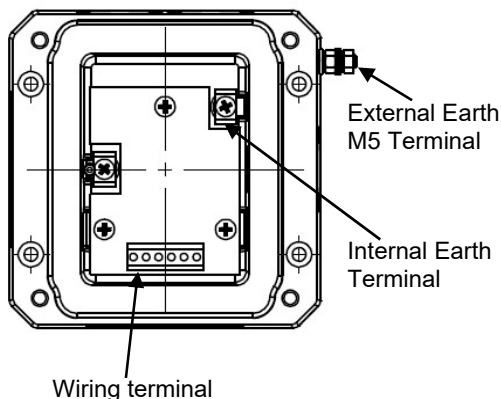

Fig 3 Earth terminals

## 9) Power Supply Selection

### Electrical Ratings

250Vac max. / 5.0A max  
 48Vdc max. / 1.0A max  
 24Vdc max / 3.0A max

A supply voltage variation of +/-10% outside the voltage range is permissible.

Electrical connections are to be made into the terminal blocks / DIN rail provided.

## 10) Selection of Cable, Cable Glands, Blanking Elements & Adapters

For high ambient temperatures the cable entry temperature may exceed +70°C or the cable branching point temperature may exceed 80°C and therefore suitable heat resisting cables and cable glands must be used, with a rated service temperature of at least the values stated below:

For Single Switch models STExCP8-PT-S / STExCP8-PM-S / STExCP8-PB-S:

Max. ambient temperature	65°C	70°C
req. Cable / Cable Gland rating:	80°C	85°C

For Dual Switch models STExCP8-PT-D / STExCP8-PM-D / STExCP8-PB-D:

Max. ambient temperature	50°C	55°C	60°C	65°C	70°C
req. Cable / Cable Gland rating:	80°C	85°C	90°C	95°C	100°C

The cable gland entries have an M20 x 1.5 entry thread. Only suitably rated and ATEX / IECEx / UKEX certified cable glands which must be suitable for the type of cable being used and also meet the requirements of the current Ex 'd' flameproof installation standards EN 60079-14 / IEC60079-14.

When only one cable entry is used the other entries must be closed with suitably rated and ATEX / IECEx / UKEX certified blanking plugs.

If a high IP (Ingress Protection) rating is required then a suitable sealing washer must be fitted under the cable glands or blanking plugs.

The STExCP8 Call Point range can be supplied with the following types of adapters:

- M20 to 1/2" NPT
- M20 to 3/4" NPT
- M20 to M25

It is important to note that stopping plugs cannot be fitted onto adapters, only directly onto the M20 entries.

Any other adapters used must be suitably rated and ATEX / IECEx / UKEX certified adapters.

## 11) Cable Connections

Electrical connections are to be made into the terminal blocks on the PCBA located in the flameproof enclosure. See section 7 of this manual for access to the flameproof enclosure.

Wires having a cross sectional area between 0.5 mm<sup>2</sup> to 2.5mm<sup>2</sup> can be connected to each terminal way.

If an input and output wire is required the 2-off Live/Neutral or +/- terminals can be used. If fitting 2-off wires to one terminal way the sum of the 2-off wires must be a maximum cross sectional area of 2.5mm<sup>2</sup>. Strip wires to 8mm. Wires may also be fitted using ferrules. Terminal screws need to be tightened down with a tightening torque of 0.45 Nm / 5 Lb-in. When connecting wires to the terminals great care should be taken to dress the wires so that when the cover is inserted into the chamber the wires do not exert excess pressure on the terminal blocks. This is particularly important when using cables with large cross sectional areas such as 2.5mm<sup>2</sup>.

## 12) Wiring Unit

The units come with two options for the terminal block. A DIN rail version which has 8-way connection and allows for limited wiring of EOL devices. The PCB Terminal Version has a 6-way connector but is designed to allow for full configuration with Series and EOL devices in a number of wiring configurations.

For EOL and Series device limitations and configurations see Section 14.

For wiring schematic see document D204-06-001

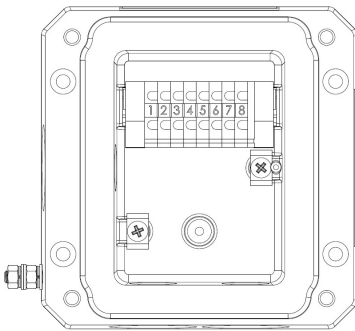

Fig. 4 DIN Rail in Base

### Wiring Diagram For 6-Way PCB Terminal Board

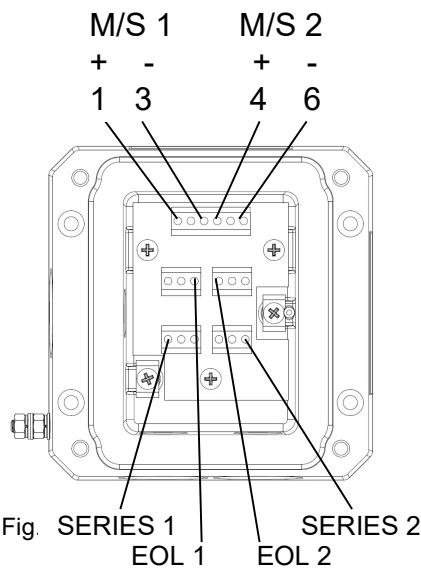

Fig. SERIES 1  
EOL 1  
SERIES 2  
EOL 2

See section 14 and page 7 for details of adding Series and EOL devices on the PCB. This can either be done at the order stage or added to the correct terminal blocks afterward (see example on sheet 7). All devices must comply with the requirements stipulated in section 14.

## 13) Testing unit operation

The push button types -PB -PT and -PM are all operated by pressing in the main plunger down activating the switch.

The -PB plunger needs to be firstly twisted by 90 degrees clockwise to position shown and then pressed in.

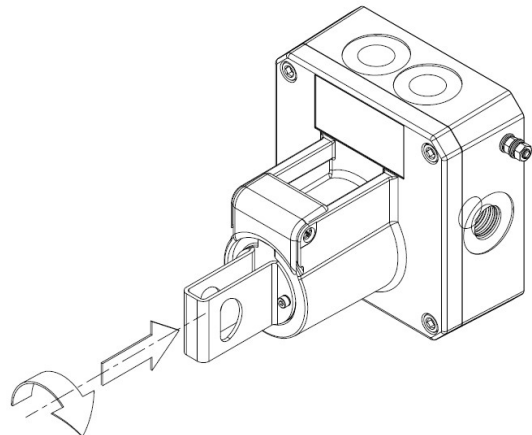

Fig 6 -PB Version Twist and Push Action

The -PM and -PT need to have the protective flip lid opened first and then the main plunger pressed in.

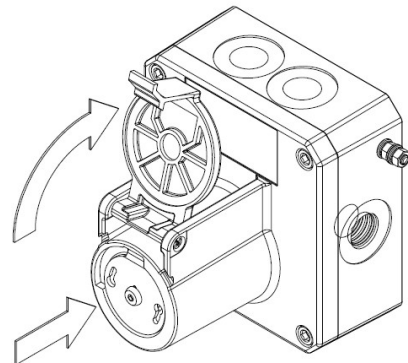
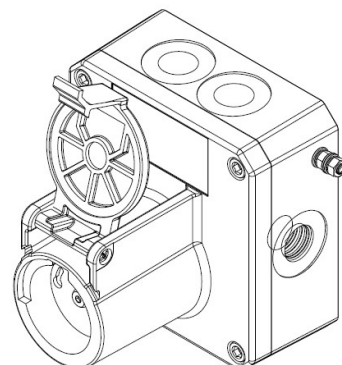

Fig 7 -PT & -PM Versions Push Action

On -PM versions the operation is momentary and as such the plunger will reset automatically once the pressure on the plunger is released.



On -PB the plunger will remain in the down position until the unit is reset. This is done by pulling the plunger back up to the start position shown in fig 6. Then the plunger is twisted back 90 degrees anti-clockwise to the stop.

On -PT the plunger will remain in the down position until the unit is reset. This is done by lifting the plunger back up using the tool reset key provided.

#### 14) End-of-Line and Series Devices

All models can be fitted with series resistors, end-of-line monitoring resistors, monitoring diodes and zener diodes if supplied with direct current up to 48Vdc.

Min. resistor values and current limitations must be observed depending on supply voltage and type of components fitted. If a combination of resistors / diodes / zener diodes is used, values for all components must be observed and lowest current limit for either component becomes overall limit. Current limitation for units fitted with end-of-line resistors, diodes or zener diodes must be ensured by using a current limited power supply or fitting a current limiting resistor at the control panel (not provided).

The following table 1 shows limitations for all possible variations:

Type of component fitted	Supply voltage 24Vdc		Supply voltage 48Vdc	
	value	Max. current	value	Max. current
End-of-Line Resistor *See note	min. 470R / 2W or min. 2k2 / 0.5W	3.0 A	min. 2k2 / 2W or min. 8k2 / 0.5W	1.0 A
End-of-Line Diode Type 1N5401	2W	59.13 mA	2W	25.26 mA
Series Resistor *See note	min. 470R / 2W or min. 2k2 / 0.5W	3.0 A	min. 2k2 / 2W or min. 8k2 / 0.5W	1.0 A
Series Diode Type 1N5401	2W	59.13 mA	2W	25.26 mA
Series Zener Diode Type 1N5333B	3.3V	230 mA	3.3V	230 mA
	4.7V	162 mA	4.7V	162 mA
	5.1V	149 mA	5.1V	149 mA
	5.6V	136 mA	5.6V	136 mA
	6.2V	122 mA	6.2V	122 mA
	6.8V	112 mA	6.8V	112 mA
	10V	76 mA	10V	76 mA
	12V	63 mA	12V	63 mA

\* note :- EOL and series resistor values are listed as the minimum resistor value allowable at the specified minimum wattage.

EOL (End of line) device;

- resistor – ExxxR
- diode – ED1
- zener – ExxxZ

Series (In line) device;

- resistor – SxxxR
- diode – SD1
- zener – SxxxZ
- LED

Microswitch 1 = M/S 1

Microswitch 2 = M/S 2

The unit can be wired with a maximum of 4 module devices – see wiring diagrams.

Note:- The maximum voltage stated must not be exceeded, as the internal resistor modules are rated as compliant with Ex d according to the units voltage

Please refer to wiring schematic D204-06-001

#### 15) Maintenance, Overhaul & Repair

Maintenance, repair and overhaul of the equipment should only be carried out by suitably qualified personnel in accordance with the current relevant standards:

- EN60079-19 Explosive atmospheres - Equipment repair, overhaul and reclamation
- IEC60079-19
- EN 60079-17 Explosive atmospheres - Electrical installations inspection and maintenance
- IEC60079-17

To avoid a possible ELECTROSTATIC CHARGE the unit must only be cleaned with a damp cloth.

Units must not be opened while an explosive atmosphere is present.

#### 16) SIL 2 Reliability Data

Reliability and Functional safety IEC/EN61508 which has been assessed and is considered suitable for use in low demand safety function:

- Random Hardware Failures and Systematic Failures (route 2H)
- As an unvoted item (i.e. hardware fault tolerance of 0) at SIL 2

The product was assessed against failure modes:

- Failure to close a contact when the call point is struck with specified force
- Failure to open a contact when the call point is struck with specified force
- Spurious output despite no input

Integrity in respect of failure to close	SIL 2
System Type	A
Hardware Fault Tolerance	0
Safe Failure Fraction (credible claim)	75%
PFD (hazardous failure)	$2.3 \times 10^{-3}$
Proof Test Interval	Up to 1 year



Nº: IEx 20.0051X

### Informações da Marca

**No. do Tipo da Unidade:** STExCP8-PT-S, STExCP8-PT-D  
STExCP8-PM-S, STExCP8-PM-D  
STExCP8-PB-S, STExCP8-PB-D

**Tensão de entrada:** Unidades CC 48Vcc  
Unidades CA 250Vca (apenas unidades sem série ou dispositivos de fim de linha)

**Códigos:** STExCP8-PT-S / STExCP8-PM-S / STExCP8-PB-S  
Ex db IIC T6 Gb Ta. -55 to +70°C  
  
STExCP8-PT-D / STExCP8-PM-D / STExCP8-PB-D  
Ex db IIC T5 Gb Ta. -55 to +70°C  
Ex db IIC T6 Gb Ta. -55 to +60°C

**Nº do Certificado.** DEMKO 15 ATEX 1589X  
IECEX ULD 15.0018X

**Marca ATEX, Grupo e Categoria do Equipamento:**  II 2G

**Nº da Marca CE e do Corpo Notificado:**  2813

### Avisos:

CLASSE DOS PARAFUSOS DA TAMPA A4-70  
NÃO ABRA QUANDO HOUVER GASES OU PÓS EXPLOSIVOS NO AMBIENTE  
POTENCIAL PERIGO DE DESCARGA ELETROSTÁTICA  
TODAS AS ENTRADAS M20 X 1,5  
SE A TEMPERATURA EXCEDER 70°C NA ENTRADA OU 80°C NO PONTO DE RAMIFICAÇÃO, USE UM CABO ADEQUADO E PRENSA-CABOS

### Normas de Aprovação:

EN60079-0:2012 e EN IEC 60079-0:2011 (Ed 6): Ambientes Passíveis de Explosão - Equipamentos. Requisitos gerais  
EN60079-1:2014 / IEC60079-1:2014 (Ed 7): Ambientes Passíveis de Explosão - Proteção do equipamento por carcaças a prova de fogo "d"

### Classificação de Área:

Zona 1	Ambiente no qual gases explosivos podem se acumular durante a operação normal.
Zona 2	Ambiente no qual não há a possibilidade de gases explosivos se acumularem durante a operação normal, mas podem ocorrer por curtos períodos.

### Grupos de Gases:

Grupo IIA	Propano
Grupo IIB	Etileno
Group IIC	Hidrogênio e Acetileno

**Categoria dos Equipamentos:** 2G

**Nível de Proteção dos Equipamentos:** Gb

## Classificação de Temperatura para Aplicações de Gases:

T1 450°C  
T2 300°C  
T3 200°C  
T4 135°C  
T5 100°C  
T6 85°C (Para modelos de comutador duplo apenas até Tamb 60°C)

## Faixas de Temperatura Ambiente:

-55°C até +70°C Grupos de Gás IIA, IIB e IIC

## Avaliações elétricas

250Vca max. / 5.0A max

48Vcc max. / 1.0A max

24Vcc max / 3.0A max

É permitida uma variação da tensão de alimentação de +/- 10% fora da faixa de tensão.

## Dispositivos de fim de linha e série

Todos os modelos podem ser equipados com resistores em série, resistores de monitoramento de fim de linha, diodos de monitoramento e diodos zener, se fornecidos com corrente contínua de até 48Vcc.

Min. os valores do resistor e as limitações de corrente devem ser observados, dependendo da tensão de alimentação e do tipo de componentes instalados.

Se uma combinação de resistores / diodos / diodos zener for usada, os valores para todos os componentes deverão ser observados e o limite de corrente mais baixo para qualquer componente se tornará o limite geral.

A limitação de corrente para unidades equipadas com resistores de fim de linha, diodos ou diodos zener deve ser garantida usando uma fonte de alimentação limitada de corrente ou instalando um resistor limitador de corrente no painel de controle (não fornecido).

A tabela a seguir mostra limitações para todas as variações possíveis:

ensão de alimentação	24Vcc		48Vcc	
	value	Max. current	value	Max. current
End-of-Line Resistor	min. 470 Ohm, 0.5W	3.0 A	min. 2200 Ohm, 0.5W	1.0 A
End-of-Line Diode Type 1N5401	2W	59.13 mA	2W	25.26 mA
Series Resistor	min. 470 Ohm, 0.5W	3.0 A	min. 2200 Ohm, 0.5W	1.0 A
Series Diode Type 1N5401	2W	59.13 mA	2W	25.26 mA
Series Zener Diode Type 1N5333B	3.3V	230 mA	3.3V	230 mA
	4.7V	162 mA	4.7V	162 mA
	5.1V	149 mA	5.1V	149 mA
	5.6V	136 mA	5.6V	136 mA
	6.2V	122 mA	6.2V	122 mA
	6.8V	112 mA	6.8V	112 mA
	10V	76 mA	10V	76 mA
12V	63 mA	12V	63 mA	

## Instalação

Os faróis deverão ser instalados somente por pessoal adequadamente qualificado em conformidade com as mais recentes publicações das normas relevantes:

EN60079-14/IEC60079-14: Ambientes Passíveis de Explosão - Projeto, seleção e construção das instalações elétricas

EN60079-10-1/IEC60079-10-1: Ambientes Passíveis de Explosão - Classificação das áreas. Ambientes com gases explosivos

EN60079-10-2/IEC60079-10-2: Ambientes Passíveis de Explosão - Classificação das áreas. Ambientes com pós explosivos

A instalação das unidades também deverá estar em conformidade com quaisquer códigos locais que possam se aplicar e só deverá ser realizada por um engenheiro elétrico competente que tenha o treinamento necessário.

O equipamento não deve ser instalado com nenhuma obstrução à junta à prova de chama flangeada o mais próximo do permitido, conforme EN / IEC60079-14, tabela 13.

Para temperaturas ambiente altas, a temperatura de entrada do cabo pode exceder + 70°C ou a temperatura do ponto de ramificação do cabo pode exceder 80°C e, portanto, devem ser utilizados cabos e buçins resistentes ao calor, com uma temperatura nominal de serviço de pelo menos os valores indicados abaixo:

STExCP8-PT-S / STExCP8-PM-S / STExCP8-PB-S		
Máx. temperatura ambiente	65°C	70°C
req. Classificação de cabos / buçins	80°C	85°C

STExCP8-PT-D / STExCP8-PM-D / STExCP8-PB-D					
Máx. temperatura ambiente	50°C	55°C	60°C	65°C	70°C
req. Classificação de cabos / buçins	80°C	85°C	90°C	95°C	100°C

A fim de acessar a câmara Ex d, remova os quatro parafusos de cabeça baixa hexagonal M6x25 e retire a capa a prova de fogo, tomando extremo cuidado para não danificar as junções a prova de fogo no processo.

As conexões elétricas devem ser feitas nos blocos de terminais / trilho DIN fornecido.

As conexões de aterramento interno devem ser feitas no terminal Terra Interno no PCBA.

O condutor de terra deve ser pelo menos igual em tamanho e classificação para os condutores de potência de entrada.

Conexões de aterramento externas devem ser feitas no terminal de aterramento M5, usando um terminal de crimpagem para fixar o condutor de aterramento ao terminal de aterramento. O condutor de terra externo deve ter pelo menos 4 mm<sup>2</sup> de tamanho.

Ao concluir a instalação das junções a prova de fogo, deve-se inspecioná-las a fim de garantir que estejam limpas e que não tenham sido danificadas durante a instalação.

As juntas à prova de chamas não devem ser reparadas.

Ao substituir a fundição da tampa a prova de fogo, garanta que esteja perfeitamente alinhada à fundição da câmara a prova de fogo antes da inserção. Cuidadosamente, empurre a tampa para a posição correta, permitindo que o ar seja expelido. Somente depois de posicionar a tampa no local correto, os quatro parafusos M5x16 da tampa (torque de aperto 8.8Nm) . Caso a tampa emperre ao ser inserida, remova-a cuidadosamente e tente mais uma vez. Nunca utilize os parafusos da tampa para forçá-la a se encaixar.

Todas as entradas M20x1,5. Quando apenas uma entrada de cabo é usada, as outras entradas devem ser fechadas com plugues de vedação adequadamente classificados e certificados pela ATEX / IECEx.

Caso uma classificação IP (proteção de inserção) seja exigida, uma arruela de selagem adequada deverá ser encaixada sob o empanque do cabo.

## Manutenção, Revisão e Reparo

A manutenção, o reparo, e a revisão dos equipamentos deverão ser realizados somente por pessoal adequadamente qualificado, em conformidade com as normas relevantes atuais:

EN60079-19    Ambientes passíveis de explosão - Reparo, revisão e recuperação de equipamentos  
IEC60079-19

EN 60079-17    Ambientes passíveis de explosão - Inspeção e manutenção de instalações elétricas  
IEC60079-17

As unidades não deverão ser abertas enquanto estiverem em um ambiente passível de explosão.

A fim de evitar uma possível DESCARGA ELETROSTÁTICA, a unidade deverá ser limpa somente com pano úmido.



1	2	3	4	5	6	7	8	9	10
<b>E2S PART NO.</b>	<b>DESCRIPTION</b>	<b>DATA REFERENCE</b>			<b>ISSUE</b>		<b>MOD No.</b>	<b>INITIAL/DATE</b>	
STExCP8 -BG	STExCP8 Ex d CALL POINT BREAK GLASS	1.24.120			1			Introduction RSR 03-07-2019	
STExCP8 -PB	STExCP8 Ex d CALL POINT PUSH BUTTON	1.24.140			2			Wiring Updated for DIN rail units. 23-03-2020	
STExCP8 -PM	STExCP8 Ex d CALL POINT MOMENTARY PUSH BUTTON	1.24.130			3			Additional Dual Switch DIN Wiring options added - DH 29-09-2020	
STExCP8 -PT	STExCP8 Ex d CALL POINT PUSH BUTTON TOOL RESET	1.24.130							
STExCP8 [ ] [S] [D]		SWITCH TYPE: [S] - Single Microswitch		TERMINAL TYPE [D] - DIN					

RAIL  
Standard Unit as supplied by E2S  
Without Series / EOL Devices

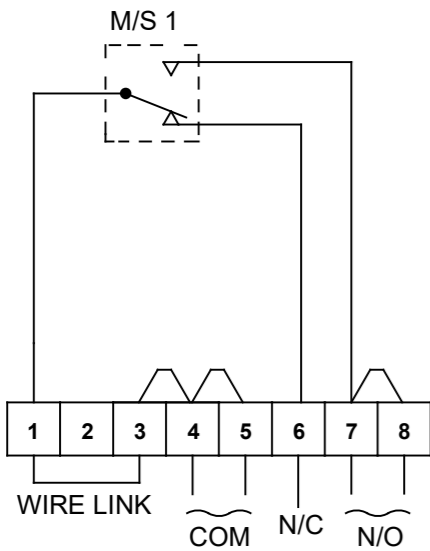

1A - Circuit as shown in Unoperated condition  
Terminals (4/5) & (7/8) open  
Terminals (4/5) & (6) closed

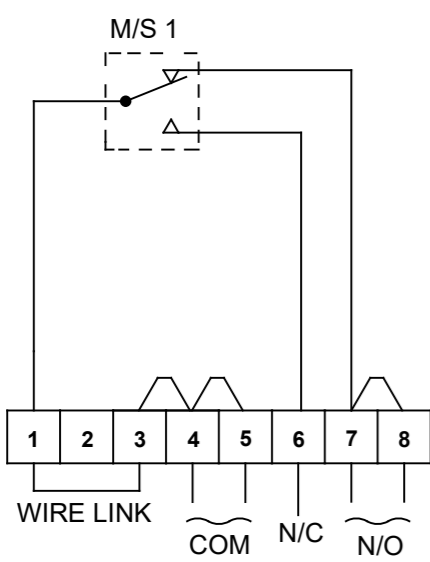

1B - Circuit as shown in Unoperated condition  
Terminals (4/5) & (7/8) closed  
Terminals (4/5) & (6) open

Standard Unit showing positions of  
optional Series / EOL Devices

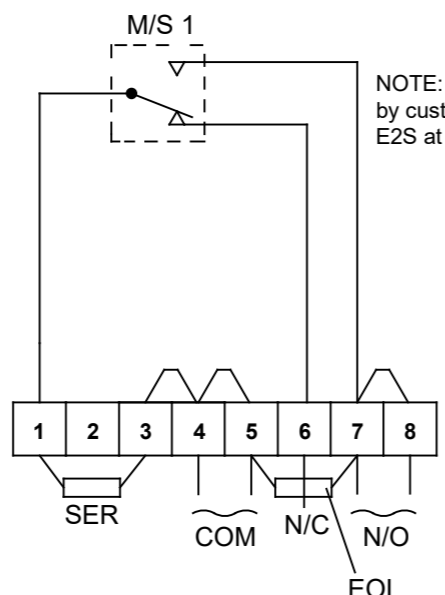

2A - Circuit as shown in Unoperated condition  
Terminals (4/5) & (7/8) open  
Terminals (4/5) & (6) closed

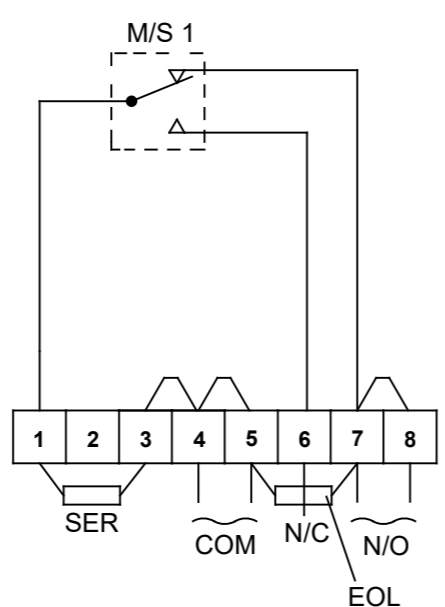

2B - Circuit as shown in Unoperated condition  
Terminals (4/5) & (7/8) closed  
Terminals (4/5) & (6) open

Wiring option shown with EOL & series devices acting in series

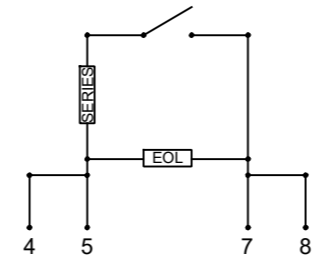

When fitting diodes or zener diodes, polarity across devices must be observed (Resistor polarity is unimportant)

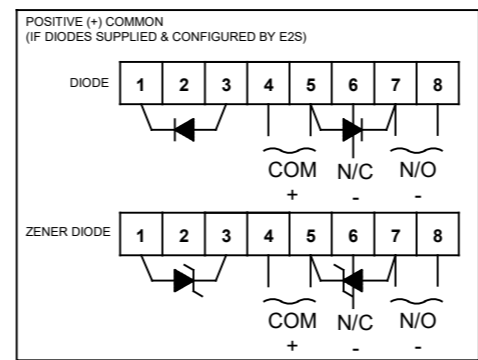

**KEY:**  
COM - Common  
N/C - Normally Closed (Contacts closed in unoperated state)  
N/O - Normally Open (Contacts open in unoperated state)

Standard Unit with suggested Series / EOL Devices - Alternative Configuration

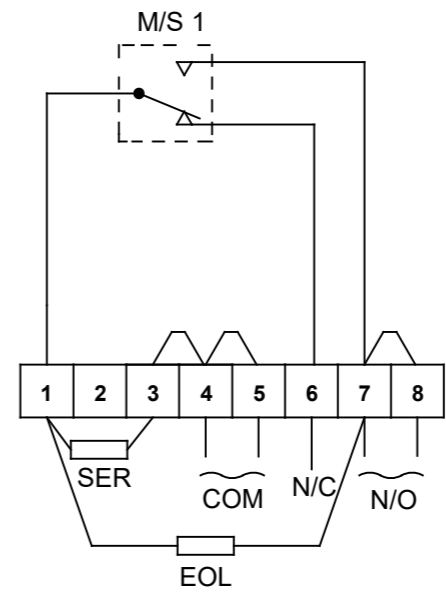

3A - Circuit as shown in Unoperated condition  
Terminals (4/5) & (7/8) open  
Terminals (4/5) & (6) closed

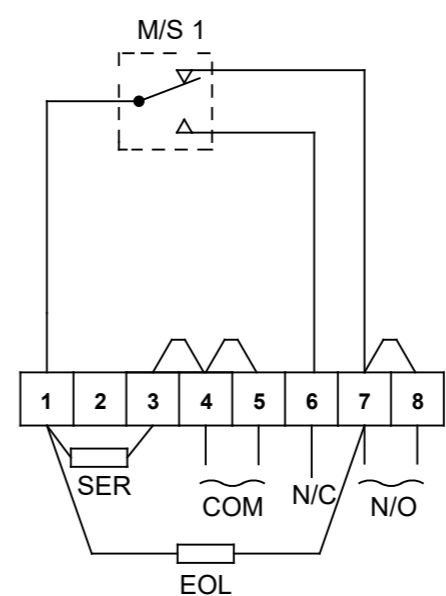

3B - Circuit as shown in Operated condition  
Terminals (4/5) & (7/8) closed  
Terminals (4/5) & (6) open

Wiring option shown with EOL & series devices acting in parallel

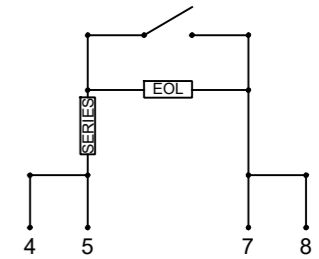

When fitting diodes or zener diodes, polarity across devices must be observed (Resistor polarity is unimportant)

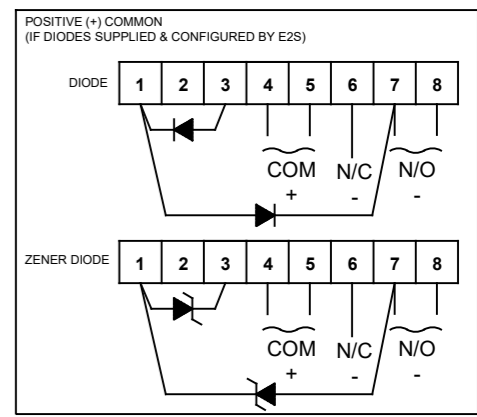

FOR PERMITTED MIN/MAX VALUES OF EOL & SERIES DEVICES, PLEASE REFER TO INSTRUCTIONS

DRAWING TO BS8888:2000  
GEOMETRIC TOLERANCES TO ISO1101:1983  
LINEAR DIMENSIONAL TOLS +/-0.35mm  
ANGULAR DIMENSIONAL TOLS +/-2 deg

DRAWN	R.S.RAIT	DATE	03-07-2019
CHECKED	B.ISARD	DATE	03-07-2019
APPROVED	R.N.POTTS	DATE	03-07-2019

SURFACE FINISH	WEIGHT (Kg)
MATERIAL	
ALTERNATIVE MATERIAL	

THIS DRAWING AND ANY INFORMATION OR DESCRIPTIVE MATTER THEREIN IS COMMUNICATED IN CONFIDENCE AND IS THE COPYRIGHT PROPERTY OF EUROPEAN SAFETY SYSTEMS LTD. NEITHER THE WHOLE OR ANY EXTRACT MAY BE DISCLOSED, LOANED, COPIED OR USED FOR MANUFACTURING OR TENDERING PURPOSES WITHOUT THEIR WRITTEN CONSENT.

© EUROPEAN SAFETY SYSTEMS LTD.  
AS PER LATEST DATE OF ISSUE SHOWN ABOVE

EUROPEAN SAFETY SYSTEMS LTD  
IMPRESS HOUSE  
MANSELL ROAD  
ACTON  
LONDON W3 7QH  
WWW.E2S.COM

ALL DIMENSIONS IN MM IF IN DOUBT, ASK - DO NOT SCALE		A3	
TITLE STExCP8 CALL POINT WIRING / CIRCUIT OPERATION DIAGRAM			
SCALE NTS	SHEET 1 OF 4	DRAWING NUMBER D204-06-001	

8	9	10
ISSUE	MOD No.	INITIAL/DATE
1		Introduction RSR 03-07-2019
2		Wiring Updated for DIN rail units. 23-03-2020
3		Additional Dual Switch DIN Wiring options added - DH 29-09-2020

STExCP8 [ ] [D] [D] SWITCH TYPE: [D] - Double Microswitch TERMINAL TYPE [D] - DIN RAIL

Standard Unit showing positions of optional EOL Devices

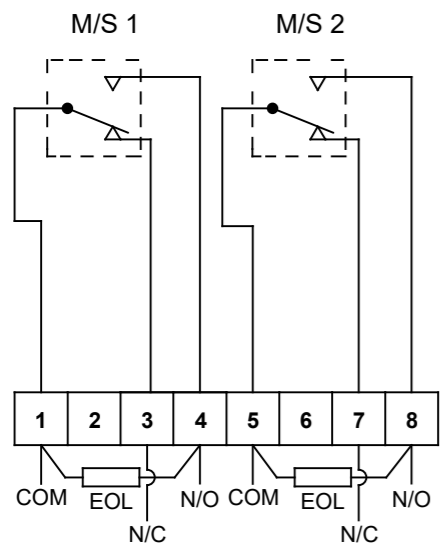

NOTE: These can be fitted either by customer or pre-installed by E2S at point of order.

When fitting diodes or zener diodes, polarity across devices must be observed (Resistor polarity is unimportant)

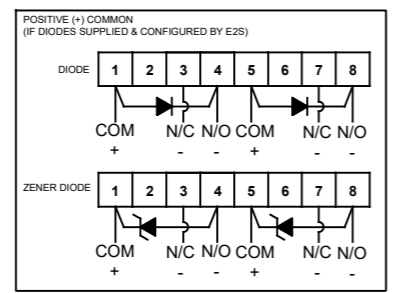

4A - Circuit as shown in Unoperated condition  
Terminals (1) & (4) M/S 1 and (5) & (8) M/S 2 open  
Terminals (1) & (3) M/S 1 and (5) & (7) M/S 2 closed

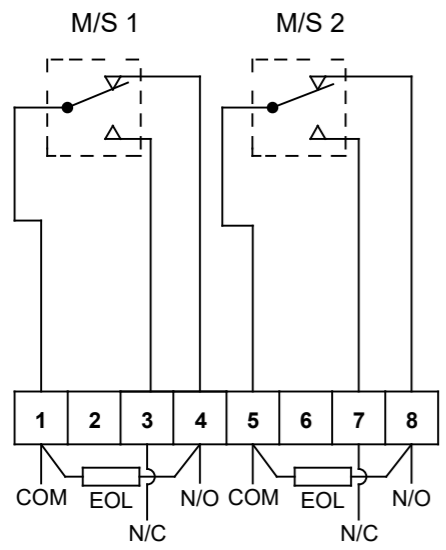

FOR PERMITTED MIN/MAX VALUES OF EOL & SERIES DEVICES, PLEASE REFER TO INSTRUCTIONS

4B - Circuit as shown in Operated condition  
Terminals (1) & (4) M/S 1 and (5) & (8) M/S 2 closed  
Terminals (1) & (3) M/S 1 and (5) & (7) M/S 2 open

Standard Unit showing positions of optional Series Devices

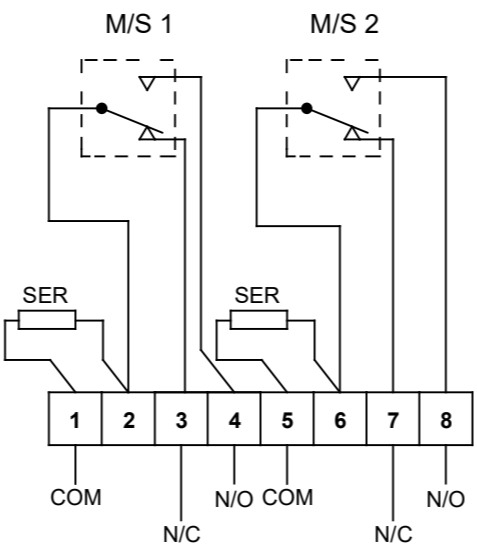

When fitting diodes or zener diodes, polarity across devices must be observed (Resistor polarity is unimportant)

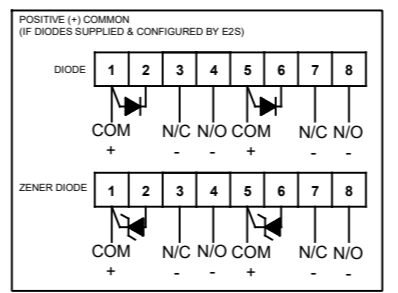

4A - Circuit as shown in Unoperated condition  
Terminals (1) & (4) M/S 1 and (5) & (8) M/S 2 open  
Terminals (1) & (3) M/S 1 and (5) & (7) M/S 2 closed

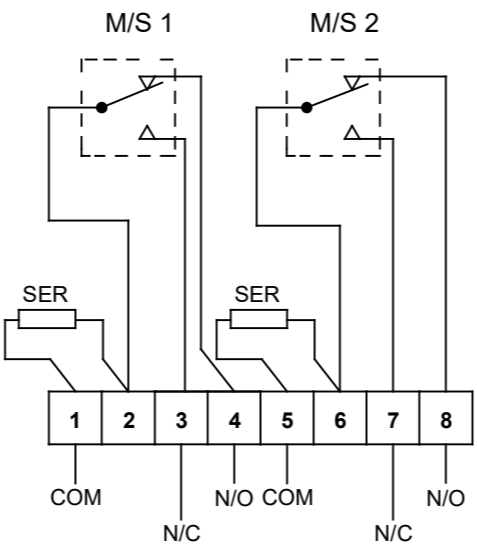

4B - Circuit as shown in Operated condition  
Terminals (1) & (4) M/S 1 and (5) & (8) M/S 2 closed  
Terminals (1) & (3) M/S 1 and (5) & (7) M/S 2 open

Standard Unit showing positions of optional Series and EOL Devices

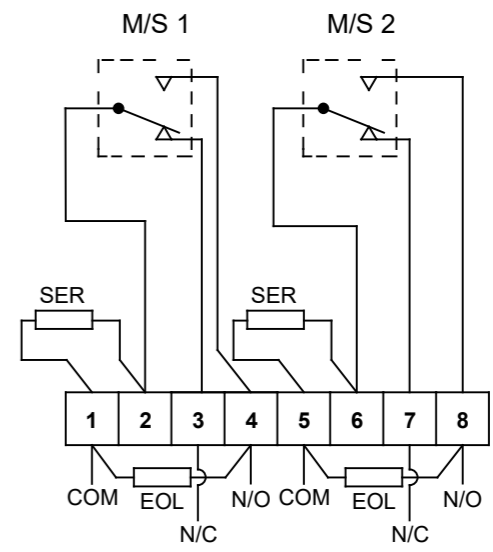

4A - Circuit as shown in Unoperated condition  
Terminals (1) & (4) M/S 1 and (5) & (8) M/S 2 open  
Terminals (1) & (3) M/S 1 and (5) & (7) M/S 2 closed

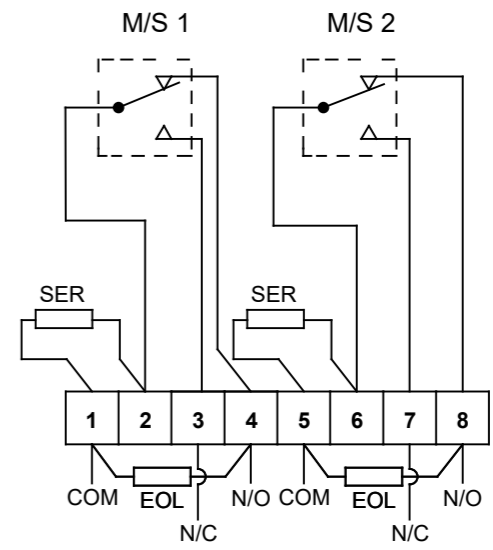

4B - Circuit as shown in Operated condition  
Terminals (1) & (4) M/S 1 and (5) & (8) M/S 2 closed  
Terminals (1) & (3) M/S 1 and (5) & (7) M/S 2 open

DRAWING TO BS8888:2000  
GEOMETRIC TOLERANCES TO ISO1101:1983  
LINEAR DIMENSIONAL TOLS +/-0.35mm  
ANGULAR DIMENSIONAL TOLS +/-2 deg

DRAWN	DATE
R.S.RAIT	03-07-2019
CHECKED	DATE
B.ISARD	03-07-2019
APPROVED	DATE
R.N.POTTS	03-07-2019

SURFACE FINISH	WEIGHT (Kg)
MATERIAL	
ALTERNATIVE MATERIAL	

THIS DRAWING AND ANY INFORMATION OR DESCRIPTIVE MATTER THEREIN IS COMMUNICATED IN CONFIDENCE AND IS THE COPYRIGHT PROPERTY OF EUROPEAN SAFETY SYSTEMS LTD. NEITHER THE WHOLE OR ANY EXTRACT MAY BE DISCLOSED, LOANED, COPIED OR USED FOR MANUFACTURING OR TENDERING PURPOSES WITHOUT THEIR WRITTEN CONSENT.

© EUROPEAN SAFETY SYSTEMS LTD.  
AS PER LATEST DATE OF ISSUE SHOWN ABOVE

**e2s**  
warning signals

EUROPEAN SAFETY SYSTEMS LTD  
IMPRESS HOUSE  
MANSELL ROAD  
ACTON  
LONDON W3 7QH  
WWW.E2S.COM

ALL DIMENSIONS IN MM IF IN DOUBT, ASK - DO NOT SCALE		A3
TITLE STExCP8 CALL POINT WIRING / CIRCUIT OPERATION DIAGRAM		
SCALE NTS	SHEET 2 OF 4	DRAWING NUMBER D204-06-001

STExCP8 [ ] [D] [D] ... [W1] SWITCH TYPE: [D] - Double Microswitch TERMINAL TYPE [D] - DIN RAIL VERSION [W1] - Special Wiring

Special Wiring  
Option A - Series & EOL on M/S 1

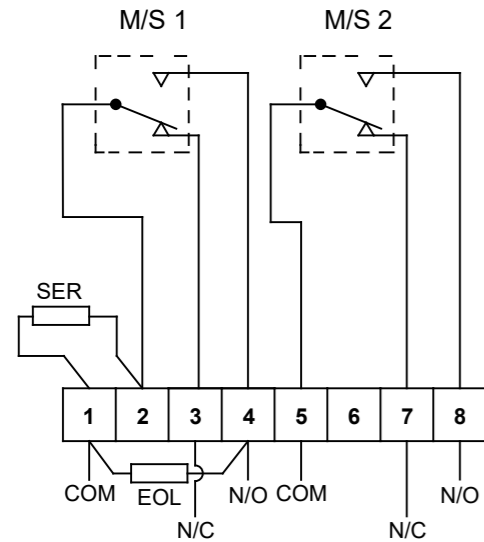

4A - Circuit as shown in Unoperated condition  
Terminals (1) & (4) M/S 1 and (5) & (8) M/S 2 open  
Terminals (1) & (3) M/S 1 and (5) & (7) M/S 2 closed

Special Wiring  
Option B - M/S 1 and M/S 2 connected

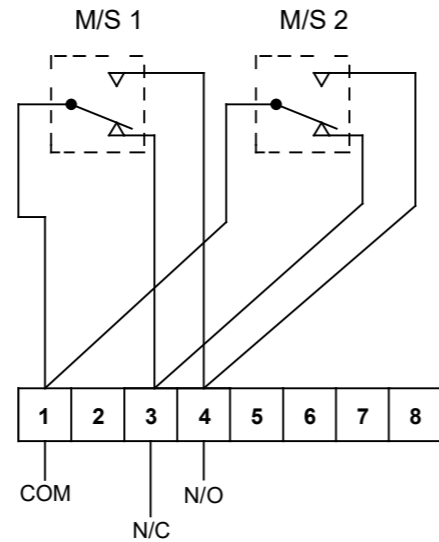

4A - Circuit as shown in Unoperated condition  
Terminals (1) & (4) M/S 1 and M/S 2 open  
Terminals (1) & (3) M/S 1 and M/S 2 closed

Special Wiring  
Option C - Series & EOL with M/S 1 and M/S 2 connected

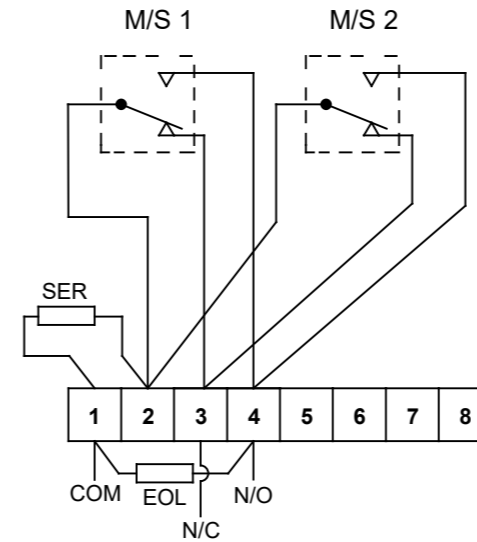

4A - Circuit as shown in Unoperated condition  
Terminals (1) & (4) M/S 1 and M/S 2 open  
Terminals (1) & (3) M/S 1 and M/S 2 closed

Other wiring configurations are available pre-configured  
Contact E2S sales for special wiring requests

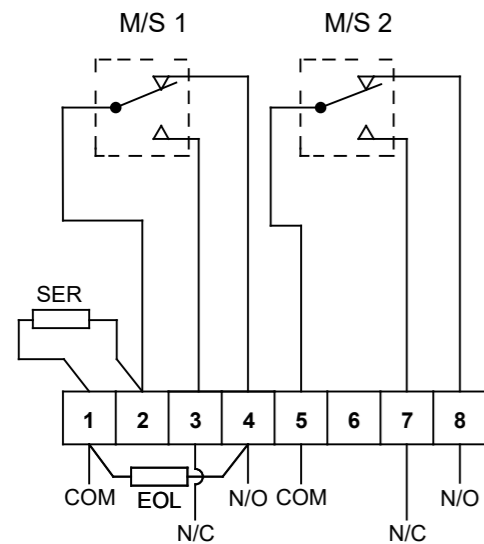

4B - Circuit as shown in Operated condition  
Terminals (1) & (4) M/S 1 and (5) & (8) M/S 2 closed  
Terminals (1) & (3) M/S 1 and (5) & (7) M/S 2 open

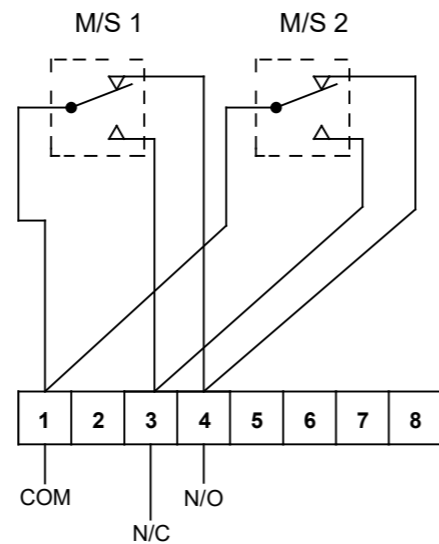

4B - Circuit as shown in Operated condition  
Terminals (1) & (4) M/S 1 and M/S 2 closed  
Terminals (1) & (3) M/S 1 and M/S 2 open

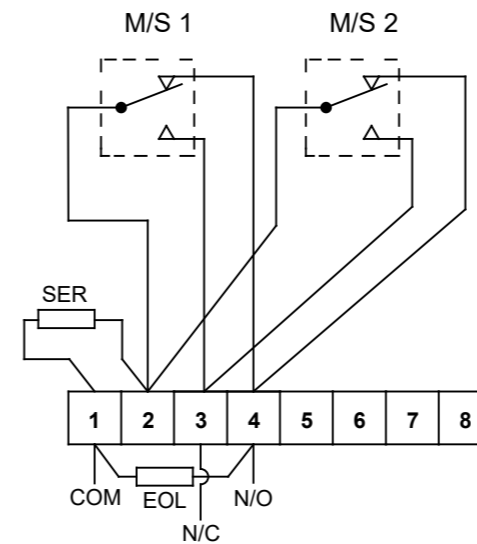

4B - Circuit as shown in Operated condition  
Terminals (1) & (4) M/S 1 and M/S 2 closed  
Terminals (1) & (3) M/S 1 and M/S 2 open

DRAWING TO BS8888:2000 GEOMETRIC TOLERANCES TO ISO1101:1983 LINEAR DIMENSIONAL TOLS +/-0.35mm ANGULAR DIMENSIONAL TOLS +/-2 deg	DRAWN R.S.RAIT	DATE 03-07-2019	SURFACE FINISH	WEIGHT (Kg)	THIS DRAWING AND ANY INFORMATION OR DESCRIPTIVE MATTER THEREIN IS COMMUNICATED IN CONFIDENCE AND IS THE COPYRIGHT PROPERTY OF EUROPEAN SAFETY SYSTEMS LTD. NEITHER THE WHOLE OR ANY EXTRACT MAY BE DISCLOSED, LOANED, COPIED OR USED FOR MANUFACTURING OR TENDERING PURPOSES WITHOUT THEIR WRITTEN CONSENT.  © EUROPEAN SAFETY SYSTEMS LTD. AS PER LATEST DATE OF ISSUE SHOWN ABOVE	 EUROPEAN SAFETY SYSTEMS LTD IMPRESS HOUSE MANSELL ROAD ACTON LONDON W3 7QH WWW.E2S.COM	ALL DIMENSIONS IN MM IF IN DOUBT, ASK - DO NOT SCALE	  A3
	CHECKED B.ISARD	DATE 03-07-2019	MATERIAL	ALTERNATIVE MATERIAL			TITLE STExCP8 CALL POINT WIRING / CIRCUIT OPERATION DIAGRAM	
	APPROVED R.N.POTTS	DATE 03-07-2019	SCALE NTS				SHEET 3 OF 4	DRAWING NUMBER D204-06-001

STExCP8 [ ] [S] [P]  
STExCP8 [ ] [D] [P]

SWITCH TYPE: [S] - Single Microswitch  
SWITCH TYPE: [D] - Double Microswitch

TERMINAL TYPE [P] - PCB  
TERMINAL TYPE [P] - PCB

FOR PERMITTED MIN/MAX  
VALUES OF EOL & SERIES  
DEVICES, PLEASE REFER TO  
INSTRUCTIONS

Optional Single or Double Microswitch

Circuit shown with Double Microswitch, Unit un-operated : STExCP8 PCB Version

Devices selected only as example:

On M/S 1: Series resistor and EOL Zener diode

On M/S 2: EOL resistor with no series device

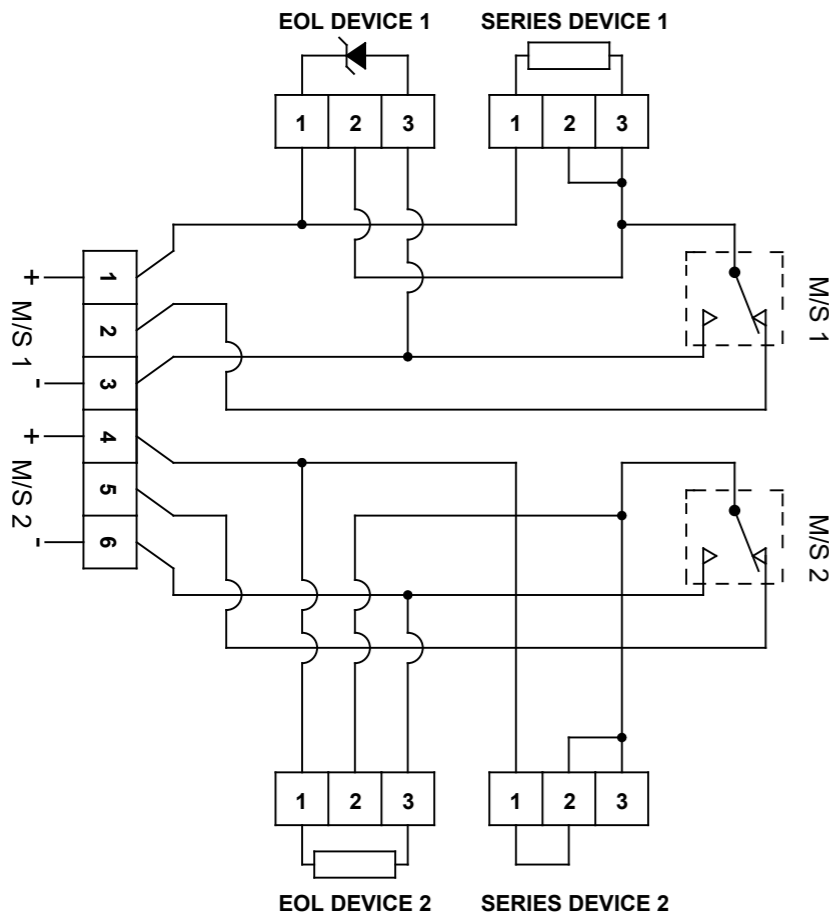
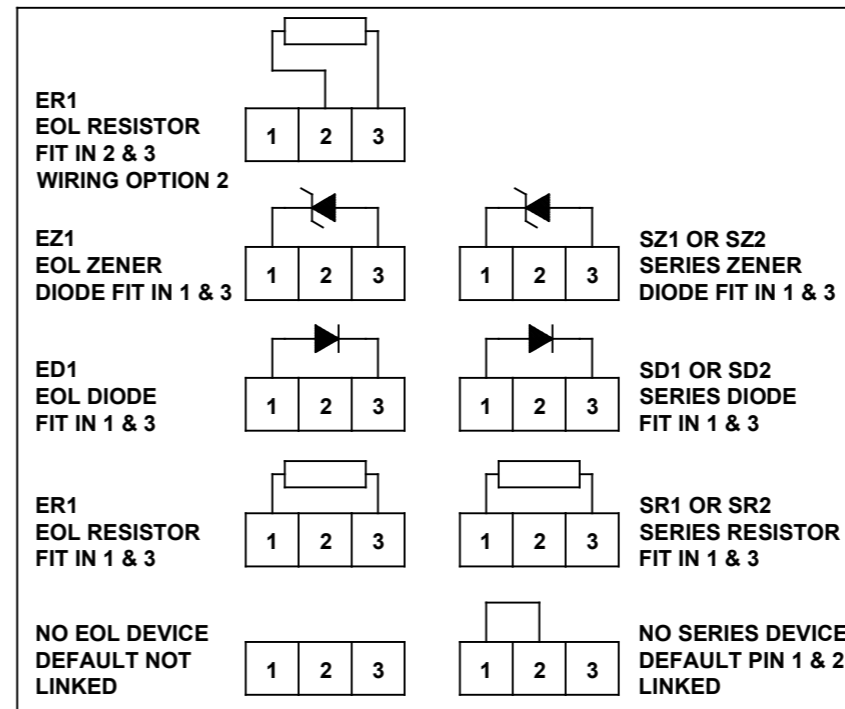

5A - Circuit as shown in Unoperated condition  
Terminals +(1) & -(3) M/S 1 and +(4) & -(6) M/S 2 open  
Terminals +(1) & (2) M/S 1 and +(4) & (5) M/S 2 closed

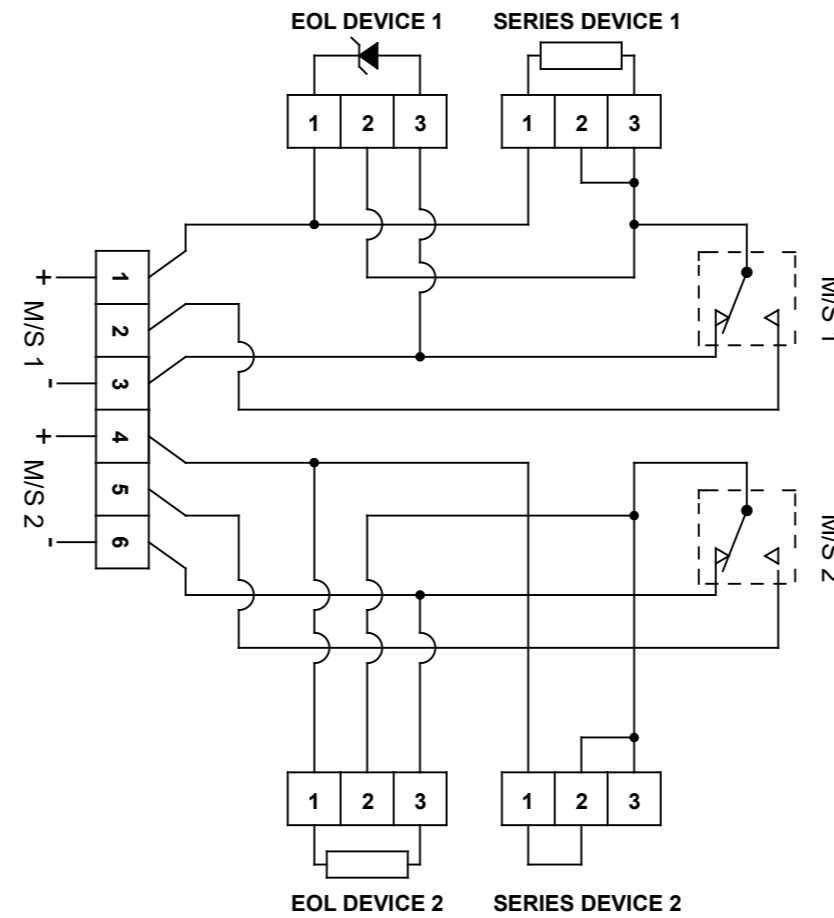

5B - Circuit as shown in Operated condition  
Terminals +(1) & (2) M/S 1 and +(4) & (5) M/S 2 open  
Terminals +(1) & -(3) M/S 1 and +(4) & -(6) M/S 2 closed

ISSUE	MOD No.	INITIAL/DATE
1		Introduction RSR 03-07-2019
2		Wiring Updated for DIN rail units. 23-03-2020
3		Additional Dual Switch DIN Wiring options added - DH 29-09-2020

DRAWING TO BS8888:2000  
GEOMETRIC TOLERANCES TO ISO1101:1983  
LINEAR DIMENSIONAL TOLS +/-0.35mm  
ANGULAR DIMENSIONAL TOLS +/-2 deg

DRAWN	R.S.RAIT	DATE	03-07-2019
CHECKED	B.ISARD	DATE	03-07-2019
APPROVED	R.N.POTTS	DATE	03-07-2019

SURFACE FINISH	WEIGHT (Kg)
MATERIAL	
ALTERNATIVE MATERIAL	

THIS DRAWING AND ANY INFORMATION OR DESCRIPTIVE  
MATTER THEREIN IS COMMUNICATED IN CONFIDENCE AND IS  
THE COPYRIGHT PROPERTY OF EUROPEAN SAFETY SYSTEMS  
LTD. NEITHER THE WHOLE OR ANY EXTRACT MAY BE  
DISCLOSED, LOANED, COPIED OR USED FOR MANUFACTURING  
OR TENDERING PURPOSES WITHOUT THEIR WRITTEN  
CONSENT.

© EUROPEAN SAFETY SYSTEMS LTD.  
AS PER LATEST DATE OF ISSUE SHOWN ABOVE



EUROPEAN SAFETY SYSTEMS LTD  
IMPRESS HOUSE  
MANSELL ROAD  
ACTON  
LONDON W3 7QH  
WWW.E2S.COM

ALL DIMENSIONS IN MM  
IF IN DOUBT, ASK -  
DO NOT SCALE

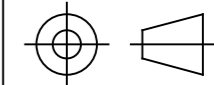

A3

TITLE  
STExCP8 CALL POINT  
WIRING / CIRCUIT OPERATION DIAGRAM

SCALE	SHEET	DRAWING NUMBER
NTS	4 OF 4	D204-06-001

# EU Declaration of Conformity



**Manufacturer:** European Safety Systems Ltd.  
Impress House, Mansell Road, Acton  
London, W3 7QH  
United Kingdom

**Authorised Representative:** E2S Warnsignaltechnik UG  
Charlottenstrasse 45-51  
72764 Reutlingen  
Germany

**Equipment Type:** STExCP8-BG-S, STExCP8-BG-D  
STExCP8-PB-S, STExCP8-PM-S, STExCP8-PT-S  
STExCP8-PB-D, STExCP8-PM-D, STExCP8-PT-D

---

## Directive 2014/34/EU: Equipment and Protective Systems for use in Potentially Explosive Atmospheres (ATEX)

Notified Body for EU type Examination (Module B):	UL International Demko A/S Notified Body No.: 0539 Borupvang 5A, 2750 Ballerup, Denmark
EU-type Examination Certificate (Module B):	DEMKO 15ATEX1589X
Notified Body for Quality Assurance Notification / Conformity to EU-type based on quality assurance of the production process (Module D):	Sira Certification Service Notified Body No.: 2813 CSA Group Netherlands B.V, Utrechtseweg 310, 6812 AR, Arnhem, Netherlands
Quality Assurance Notification (Module D):	SIRA 05 ATEX M342
Provisions fulfilled by the equipment:	II 2G Ex db IIC T5 Gb II 2G Ex db IIC T6 Gb
Standards applied:	EN 60079-0: 2012 + A11: 2013 EN 60079-1: 2014

## Directive 2014/30/EU: Electromagnetic Compatibility Directive (EMC)

Standards applied:	EN 61000-6-1:2007 EN 61000-6-2:2005 EN 61000-6-3:2007 / A1:2011 / AC: 2012 EN 61000-6-4:2007 / A1: 2011
--------------------	--

## Directive 2011/65/EU: Restriction of the use of certain hazardous substances in electrical and electronic equipment (RoHS)

The product and all the components contained within it are in accordance with the restriction of the use of hazardous substances in electrical and electronic equipment, including amendment by Directive 2015/863/EU.

## Regulation (EC) 1907/2006: Registration, Evaluation, Authorisation and Restriction of Chemicals (REACH)

The product and all the components contained within it are free from substances of very high concern.

## Other Standards and Regulations

EN 60529:1992+A2:2013 - Degrees of protection provided by enclosures (IP code) – enclosure rated IP66

# EU Declaration of Conformity



---

On behalf of European Safety Systems Ltd., I declare that, on the date the equipment accompanied by this declaration is placed on the market, the equipment conforms with all technical and regulatory requirements of the above listed directives, regulations and standards.

This Declaration is issued under the sole responsibility of the manufacturer.

A handwritten signature in black ink, appearing to read 'Martin Streetz'.

Martin Streetz  
Quality Assurance Manager

Document No.: DC-071\_Issue\_D  
Date and Place of Issue: London 23/12/2020



# UKCA Declaration of Conformity



Manufacturer: European Safety Systems Ltd.  
Impress House, Mansell Road, Acton  
London, W3 7QH  
United Kingdom

Equipment Type: STExCP8-BG-S, STExCP8-BG-D  
STExCP8-PB-S, STExCP8-PM-S, STExCP8-PT-S  
STExCP8-PB-D, STExCP8-PM-D, STExCP8-PT-D

---

Directive UKSI 2016:1107 (as amended by UKSI 2019:696) – Schedule 3A, Part 1 : Product or Protective System Intended for use in Potentially Explosive Atmospheres (UKCA)

Notified Body for UK type Examination (Module B):	UL International (UK) Ltd Notified Body No.: 0843 Unit 1-3 Horizon Kingsland Business Park, Wade Road, Basingstoke, Hampshire RG24 8AH UK
UK-type Examination Certificate (Module B):	UL21UKEX2133X
Notified Body for Quality Assurance Notification / Conformity to EU-type based on quality assurance of the production process (Module D):	Sira Certification Service Notified Body No.: 0518 Rake Lane, Eccleston, Chester CH4 9JN, UK
Quality Assurance Notification (Module D):	CSAE 22UKQAN0046
Provisions fulfilled by the equipment:	II 2G Ex db IIC T5 Gb II 2G Ex db IIC T6 Gb
Standards applied:	EN IEC 60079-0:2018 EN 60079-1: 2014

Directive 2014/30/EU: Electromagnetic Compatibility Directive (EMC)

Standards applied:	EN 61000-6-1:2007 EN 61000-6-2:2005 EN 61000-6-3:2007 / A1:2011 / AC: 2012 EN 61000-6-4:2007 / A1: 2011
--------------------	--

Directive 2011/65/EU: Restriction of the use of certain hazardous substances in electrical and electronic equipment (RoHS)

The product and all the components contained within it are in accordance with the restriction of the use of hazardous substances in electrical and electronic equipment, including amendment by Directive 2015/863/EU.

Regulation (EC) 1907/2006: Registration, Evaluation, Authorisation and Restriction of Chemicals (REACH)

The product and all the components contained within it are free from substances of very high concern.

Other Standards and Regulations

EN 60529:1992+A2:2013 - Degrees of protection provided by enclosures (IP code) – enclosure rated IP66

---

On behalf of European Safety Systems Ltd., I declare that, on the date the equipment accompanied by this declaration is placed on the market, the equipment conforms with all technical and regulatory requirements of the above listed directives, regulations and standards.

This Declaration is issued under the sole responsibility of the manufacturer.

Martin Streetz  
Quality Assurance Manager

Document No.: DC-101\_Issue\_A  
Date and Place of Issue: London 24/02/2022