

Audible Signals - Intrinsically Safe ELECTRONIC SOUNDER



Intrinsically Safe > Electronic Sounder IS-S Series

Product overview

The IS electronic sounder has been approved for use in potentially explosive atmospheres for Group I (Mining) & Group II (Above Ground) applications and incorporates a high Ingress Protected IP66 enclosure.

This range is suitable for Fire, Security, Process Control and general signalling applications and is approved to EN54-3.

The sounder unit incorporates a Two stage alarm option and has a total of 32 selectable tones, selectable via a dip switch on the PCB and produces up to 105dB at 1 Meter.

A specially designed time saver base enables quick and easy installation of this unit with no extra cabling to be made to the head of the unit.

Connections are made to the base during the initial wiring phase which results in a faster more reliable installation. The sounder head simply twists & clicks into the pre-fixed base on commissioning avoiding any additional wiring & connections. Further details can be found on the installation sheet.

This unit must be used in conjunction with an approved Zener Barrier or Galvanic Isolator. See page 2 for further information & ordering details.

Features/Certifications

- Approved by ATEX, IECEx & UKCA
- Group I MI Ex ia I Ma
- Group II IGD Ex ia IIC T6 Ga
Ex ia IIIC T85°C Da
- Zones 0, 1, 2, 20, 21 & 22
- Conforms to:
EN 60079-0:2012 + A1:2013 (IEC 60079-0:2011)
EN 60079-11:2012 + (IEC 60079-11:2011)
- Approved by BRE LPCB
- EN 54-3: 2001 + A1:2002 + A2:2006 (CE)
- EN 54-3: 2014 + A1:2019 (UKCA)
- Diode Polarised & End of line resistor compatible
- White version available (MOQ apply)
- Dustproof & Weatherproof

IS-S Series > Ordering Information

Code No:	Voltage:	Tones:	Current:
IS-S-02	16-28v DC --- (Via Suitable Zener Barrier or Galvanic Isolator)	32	33mA

Kg 0.33

°C -40+55

IP 66

INDUSTRIAL

MARINE

FIRE

APPROVALS and
CONFORMITIES



Issue 4

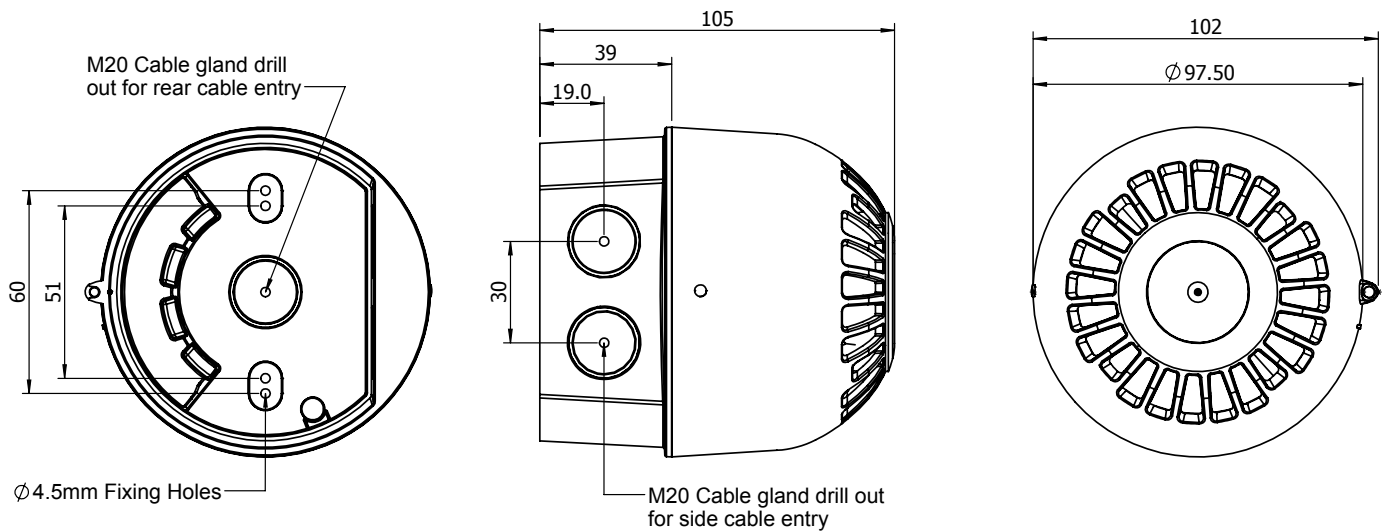

Intrinsically Safe > Electronic Sounder IS-S Series

General Information

EX CODE:	Ex ia I Ma, Ex ia IIC T6 Ga, Ex ia IIIC T85°C Da
CERTIFICATION:	ATEX (EMT17ATEX0012X) IECEx (EMT 17.0005X) UKCA (EMA21UKEX0022X)
TYPE:	Electronic Sounder
SOUNDER:	2 Stage alarm with 32 Selectable tones
POWER RATING:	0.66 Watts via a suitable barrier
SOUND OUTPUT:	Up to 105 dB at 1 meter (Tone 18)
AMBIENT TEMPERATURE:	-40°C to +55°C
HUMIDITY:	>90% at 20°C

Mechanical Specifications

MATERIAL:	Flame Retardant Polycarbonate UL94 V2
ENCLOSURE COLOUR:	RED as standard White (MOQ applies)
WEIGHT:	0.33 Kg / 0.73 lb
DIMENSIONS:	Length: 104mm x 97.5mm / 4.09" x 3.84"
INGRESS PROTECTION:	IP 66

Electrical Specifications

POWER SUPPLY:	The unit must be powered via an approved Zener Barrier or Galvanic Isolator whose characteristics do not exceed U_o: 28v, I_o: 93mA, P_o: 660mW, Ci: 0, Li 0
TERMINATION:	0.55mm up to 2.5mm
CABLE ENTRY:	3 x M20.

Accessories

	Description	Order Number	Article No.
Zener Barriers	Single Channel DC	Z 728	071788
	Single Channel AC	Z 928	071857
Galvanic Isolator	Single Channel	KCDO-SD3-Ex1.1045	304983
	Dual Channel	KFDO-SD2-Ex2.1045	242032
Relay Module	Dual Channel	KFDO-RO-Ex2	038975
Cable Gland	M20 Nylon Cable Gland >IP66		50224
Lock Nut	M20 Flanged		C00039

System Installation

The Sounder must be installed in accordance with the latest EN 60079-0 & EN 60079-11 standards or equivalent IEC standards, with consideration for any local installation requirements, and should only be carried out by appropriately competent and qualified personnel.

Moflash Signalling is not able to offer any assistance with additional system parameters beyond that included on the installation sheet, and can not give advise on individual system installations. The system integrators should be contacted for any additional installation requirements.