



Conventional Marine Indoor Manual Call Point Installation Guide

General

The Conventional Marine Indoor Manual Call Point-Red, part number 55100-021 MAR, model number MCP2A-R470SF-A071-02 is supplied with a backbox for surface mounting. The call point is 'Type A' and is suitable for indoor use only. For flush mounting, a standard electrical outlet box with a minimum depth of 25mm is required.

Installation – General

The installation must conform to BS5839: Part 1 (or applicable local codes).

Installation

1. Fit the backbox (**Fig 1**) to the wall.
2. Run the cables into the backbox and connect them to the terminal block as shown in **Fig 2**. Ensure that functional earth/screen continuity is maintained.
3. Unlock the small front cover by inserting the forked key and pushing it home. Remove key, slide the cover down and remove the deformable element. Connect the terminal block as shown in Fig. 2, secure the call point to the backbox and refit the deformable element as required. Finally, replace the front cover in the reverse order in which it was removed and push it up until it locks.

Transparent Hinged Cover (flip lid)

To provide additional protection against accidental operation of call points, a transparent hinged cover, part no. 26729-152 is available.

To prevent against malicious activations of call points, locking tags are also available, part no. 26729-179.

Please note that the call point does not conform to EN54-11 : 2001 when the hinged cover is secured with the locking tag.

Commissioning

Test each MCP using the test key provided. Ensure the control panel enters the alarm state.

Wiring Details

All wiring terminals accept solid or stranded cables up to 2.5mm².

Technical data

Maximum Voltage	30VDC
Maximum Switching Current	2A
Alarm Resistor	470 Ω / 1W
IP rating	IP24D
Operating Temperature	-10°C to 55°C

Troubleshooting

Before investigating individual units for faults, ensure the system wiring is fault free.

Routine testing

Insert the test key into the hole at the bottom of the call point and push home. Observe routine test requirements as specified in the applicable local codes.

Resetting

After testing, reset the call point by removing the test key and pushing up the front cover until it clicks home.

Important Information

The use of lubricants, cleaning solvents or petroleum based products should be avoided. Do not over tighten fixing screws.

General Fault Finding

Problem	Possible Cause
Control panel reports zone fault	Incorrect zone wiring Detector removed
Control panel reports alarm	EOL device missing or incorrectly fitted MCP not reset Test key not removed
MCP does not activate alarm	Incorrect EOL device Incorrect wiring Incompatible control panel

For further information, please refer to PP2419.

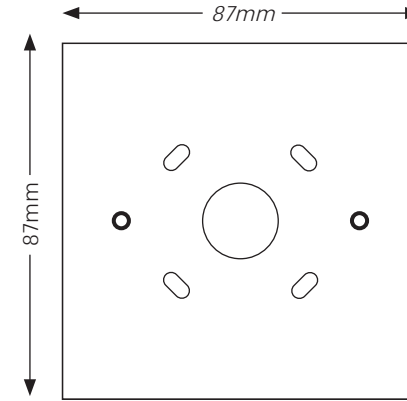

Fig 1 Backbox

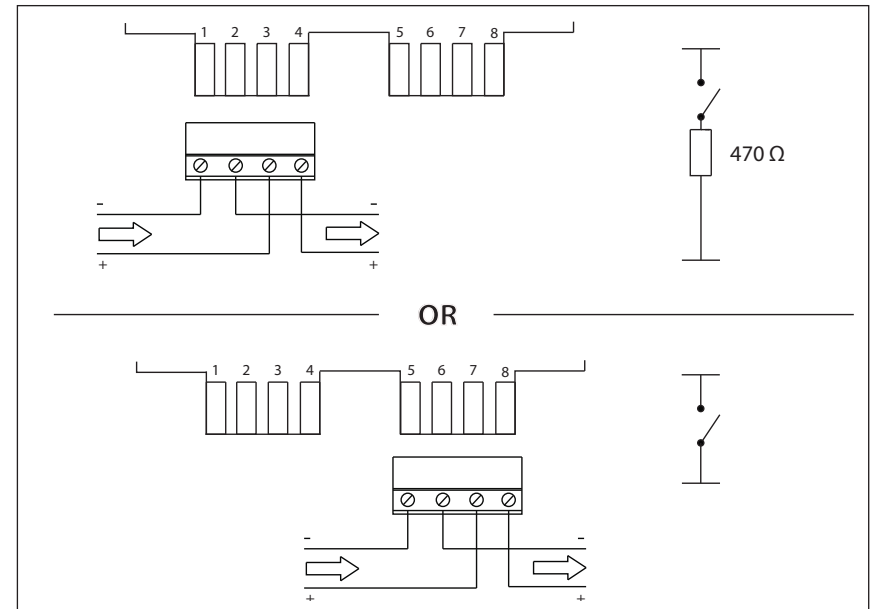

Fig 2 Terminal block connections