

**INSTRUCTION MANUAL**  
**GNExH1-I & GNExH1-IR Heat Detector**  
**Class I Div 1 ; UL521 ; CAN/ULC-S530**  
**NEC / CEC / ATEX / IECEx / UKEx Zone 0, 1, 2, 21, 22**

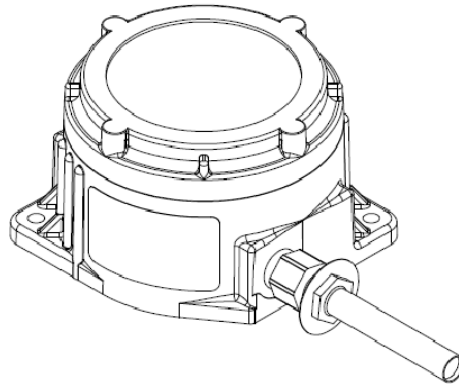

**1) Product Table**

Unit Type Code	Input Parameters
GNExH1-I	U <sub>i</sub> = 30V
GNExH1-IR	I <sub>i</sub> = 500mA
	P <sub>i</sub> = 1100mW
	C <sub>i</sub> = 0
	L <sub>i</sub> = 0

Table 1: Electrical Ratings

**2) Warnings**



**WARNINGS:**

- DO NOT OPEN WHEN AN EXPLOSIVE ATMOSPHERE IS PRESENT
- DO NOT OPEN WHEN ENERGISED
- POTENTIAL ELECTROSTATIC HAZARD – SEE INSTRUCTIO CLEAN ONLY WITH A DAMP CLOTH

**AVERTISSEMENT:**

- NE PAS OUVRIR UN PRESENCE D'ATMOSPHERE EXPLOSIVE
- NE PAS OUVRIR ENERGIE
- DANGER POTENTIEL CHARGE ÉLECTROSTATIQUE - NETTOYER UNIQUEMENT AVEC UN CHIFFON HUMIDE

### 3) Marking & Rating Information

The GNEXH1-I & GNEXH1-IR Heat Detectors comply with the following standards for hazardous locations:



All models are approved for Fire Alarm System use:

UL 521  
CAN/ULC-S530

#### 3.1 Class/Division Ratings for US & Canada

Standards	
UL 60079-0:2017 (Ed 6): Explosive Atmospheres - Part 0: Equipment - General requirements UL 60079-11:2023 (Ed6): Explosive Atmospheres - Part 1: Equipment protection by Intrinsic Safety UL 60079-31:2012 (Ed 2): Explosive Atmospheres - Part 31: Equipment dust ignition protection by enclosure "t"  CSA C22.2 NO. 60079-0:2015 (Ed 3) Explosive Atmospheres – Part 0: Equipment – General requirements CSA C22.2 NO. 60079-11:2014 (Ed 3): Explosive Atmospheres – Part 11: Equipment protection by Intrinsic Safety CSA C22.2 NO. 60079-31:2015 (Ed 2): Explosive Atmospheres – Part 31: Equipment dust ignition protection by enclosure “t”  UL 913 (Ed 8) Rev 05/10/2022 : Intrinsically Safe Apparatus and Associated Apparatus For Use in Class I, II, and III, Division 1, Hazardous (Certified) Locations	
Class Division Ratings for US (NEC) & Canada (CEC)	
Model No:	Rating
GNEXH1-I	Class I Div 1 GR. ABCD T6 Ta -50°C to +70°C Class II Div 1 GR. FG T6 Ta -50°C to +70°C Class III Div 1 Ta -50°C to +70°C
GNEXH1-IR	Class I Div 1 GR. ABCD T4 Ta -50°C to +70°C Class II Div 1 GR. FG T4 Ta -50°C to +70°C Class III Div 1 Ta -50°C to +70°C
Class Zone Ratings for US (NEC)	
Model No:	Rating
GNEXH1-I	Class I Zone 0 AEx ia IIC T6 Ga Ta -50°C to +70°C Zone 21 AEx tb IIIC T80°C Db Ta -50°C to +70°C
GNEXH1-IR	Class I Zone 0 AEx ia IIC T4 Gb Ta -50°C to +70°C Zone 21 AEx tb IIIC T80°C Db Ta -50°C to +70°C
Class Zone Ratings for Canada (CEC)	
Model No:	Rating
GNEXH1-I	Ex ia IIC T6 Ga Ta -50°C to +70°C Ex tb IIIC T80°C Db Ta -50°C to +70°C
GNEXH1-IR	Ex ia IIC T4 Gb Ta -50°C to +70°C Ex tb IIIC T80°C Db Ta -50°C to +70°C
Installation must be carried out in compliance with the National Electric Code / Canadian Electric Code	

#### 3.2 ATEX / IECEx & UKEx Ratings

Standards	
EN60079-0:2018/IEC60079-0:2017 (ed.7): Explosive Atmospheres - Equipment General Requirements. EN60079-11:2012/IEC60079-11:2019 (ed.6): Explosive Atmospheres - Equipment Protection by Intrinsically Safe Enclosures “ia”. EN60079-31:2014/IEC60079-31:2022 (ed.3): Explosive Atmospheres - Equipment Dust Ignition Protection by enclosure “t”.	
Model No:	Rating
GNEXH1-I	Ex ia IIC T6 Ga Ta -50°C to +70°C Ex tb IIIC T80°C Db Ta -50°C to +70°C
GNEXH1-IR	Ex ia IIC T4 Gb Ta -50°C to +70°C Ex tb IIIC T80°C Db Ta -50°C to +70°C
See Product table for electrical ratings of each unit model	

Certificate No. DEMKO 15 ATEX 1448X  
IECEx ULD 15.0003X  
UL21UKEX2136X

Epsilon x Equipment Group and Category:  II 1G  
II 2D

CE Marking and Notified Body No.  2813

UKCA Marking and Notified Body No.  0518

#### 4) Zones, Gas Group, Category and Temperature Classification

The units can be installed in locations with the following conditions:

Area Classification Gas	
Zone 0	Explosive gas air mixture continually present in normal operation.
Zone 1	Explosive gas air mixture likely to occur in normal operation.
Zone 2	Explosive gas air mixture not likely to occur in normal operation, and if it does, it will only exist for a short time.
Gas Groupings	
Group IIA	Propane
Group IIB	Ethylene
Group IIC	Hydrogen and Acetylene
Temperature Classification for Gas Applications	
T1	450° C
T2	300° C
T3	200° C
T4	135° C
T5	100°C (GNExH1-I only)
T6	85°C (GNExH1-I only)
Area Classification Dust	
Zone 21	Explosive dust air mixture likely to occur in normal operation.
Zone 22	Explosive dust air mixture not likely to occur in normal operation, and if it does, it will only exist for a short time.
Dust Groupings	
Group IIIA	Combustible Dusts
Group IIIB	Non-Conductive Dusts
Group IIIC	Conductive Dusts
Equipment Category	
1G, 2D	
Equipment Protection Level	
Ga, Gb, Gc, Db, Dc	
Maximum Surface Temperature for Dust Applications	
T80°C	
Ambient Temperature Range	
-50°C to +70°C (-58°F to +158°F)	
IP Rating	
IP66/67 to EN/IEC60529 and IP6X to EN/IEC60079-0, EN/IEC60079-31 4 / 4X / 3R / 13 to UL50E / NEMA250	

#### 5) Special Conditions of Use

Special Condition for safe Use as stated on the Type Examination Certificate DEMKO 15 ATEX 1448X / IECEx ULD 15.0003X & UL21UKEX2136X

Guidance on protection against the risk of ignition due to electrostatic discharge can be found in EN TR50404 and IEC TR60079-32.

End user shall adhere to the manufacturer's installation and instruction when performing housekeeping to avoid the potential for hazardous electrostatic charges during cleaning, by using a damp cloth.

The equipment does not provide 500V isolation between the intrinsically safe circuit and parts which may be earthed. This shall be considered in the end-use application to ensure the possibility of an earth connection will not compromise intrinsic safety. Refer to EN/IEC 60079-14.

Accessible metal parts are capable of retaining a stored capacitance of 10pF therefore the end user shall take the appropriate action to reduce the risks of ignition associated with discharging this capacitance.

The enclosure is non-conducting and may generate an ignition-capable level of electrostatic charges under certain extreme conditions. The user should ensure that the equipment is not installed in a location where it may be subjected to external conditions that might cause a build-up of electrostatic charges on non-conducting surfaces.

#### 6) Location and Mounting

The location of the heat detector should enable ease of access for operation and testing. They should only be fixed to services that can carry the weight of the unit.

The GNEx heat detector should be securely bolted to a flat surface using the 9.0mm diameter bolt holes in the base of the unit. See figure 2.

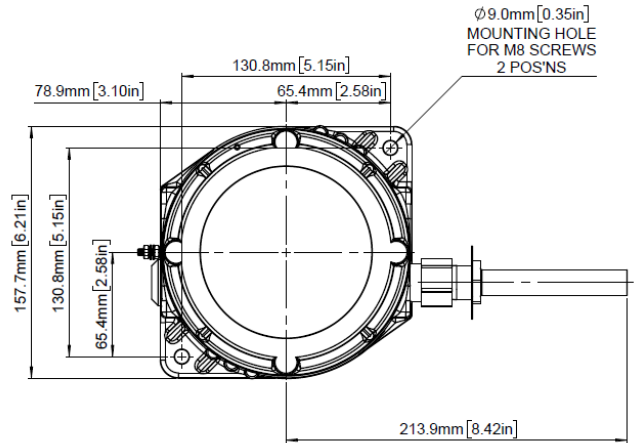

Fig. 2: Fixing Location for Junction Box.

The Heat detector element / shell should be mounted with the following consideration :-

The Heat Detector is fitted in an area (normally ceiling) so that:-

- The thermal air path to the shell is not obstructed.
- The heat detectors spacing complies with both system requirements and requirements of the local authority having jurisdiction.
- The element shell is not position sensitive, so can be mounted either vertically or horizontally depending on the application and installation requirements.

## 7) Access to the Enclosure



Warning – High voltage may be present, risk of electric shock. DO NOT open when energised, disconnect power before opening.

To access the enclosure terminals, loosen the M4 grub screw on the heat detector cover. Open the enclosure by turning the heat detector cover counterclockwise and remove the cover.

Ensure the O-ring seal is in place and undamaged.

When fitting the cover ensure the thread is engaged correctly. Fully tighten the cover all the way, ensure no gap is visible between the cover and base of the heat detector.

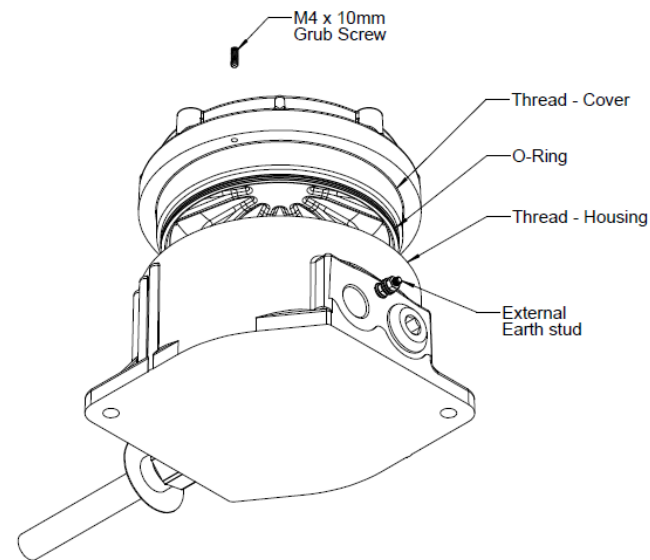

Fig. 3: Accessing the Enclosure.

## 8) Earthing

The unit has both internal and external earth terminals.

Internal earthing connections should be made to the Internal Earth terminal in the base of the housing using a ring crimp terminal to secure the earth conductor under the earth clamp. The earth conductor should be at least equal in size and rating to the incoming power conductors.

External earthing connections should be made to the M5 earth stud, using a ring crimp terminal to secure the earth conductor to the earth stud. The external earth conductor should be at least 4mm<sup>2</sup> in size.

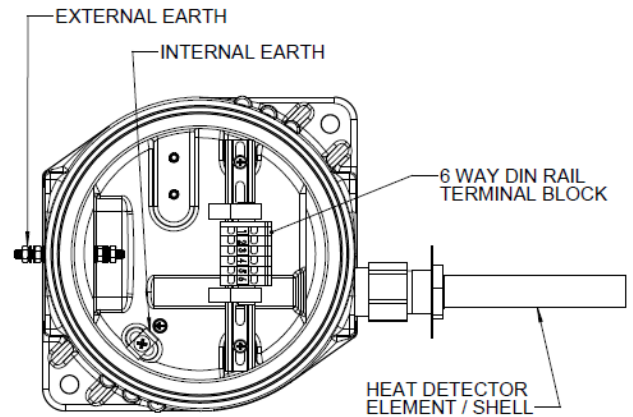

Figure 4: Earth Internal & External

## 9) Power Supply Selection

### Electrical Ratings

#### Input terminals and Zener Barrier or Galvanic Isolator

Power is supplied to the heat detector via the + and – terminals. All terminals have the following input safety parameters:

U <sub>i</sub>	=	30V
I <sub>i</sub>	=	500mA
P <sub>i</sub>	=	1100mW
C <sub>i</sub>	=	0
L <sub>i</sub>	=	0

See table 1

The unit may be powered from an ATEX/IECEX/UKEx and/or NEC/CEC certified Zener barrier or galvanic isolator which have output parameters equal to or less than 30V, 500mA and 1100mW, where I<sub>o</sub> is resistively limited. The cable parameters stated on the selected Zener barrier or galvanic isolator certificate must be observed.

## 10) Selection of Cable. Cable Glands, Blanking Elements & Adapters

### ATEX/IECEX & UKEx Installations:

The equipment must only be installed by suitably qualified personnel in accordance with the latest issues of the relevant standards:

EN60079-14 / IEC60079-14: Explosive atmospheres - Electrical installations design, selection and erection  
 EN60079-10-1 / IEC60079-10-1: Explosive atmospheres - Classification of areas. Explosive gas atmospheres

The installation of the units must also be in accordance with any local codes that may apply and should only be carried out by a competent electrical engineer who has the necessary training.

For high ambient temperatures the cable entry temperature may exceed +70°C or the cable branching point temperature may exceed 80°C and therefore suitable heat resisting cables

and cable glands must be used, with a rated service temperature of at least the values stated below:

For model GNExH1-I:

Max. ambient temperature °C	60	65	70
req. Cable / Cable Gland rating: °C	70	75	80

For model GNExH1-IR:

Max. ambient temperature °C	50	55	60	65	70
req. Cable / Cable Gland rating: °C	70	75	80	85	90

The cable entries have an M20 x 1.5 – 6H entry thread.

The cable gland entries have an M20 x 1.5 entry thread. Glands to be rated to IP66

When only one cable entry is used the other entries must be closed with plugs to be rated to IP66

NEC / CEC Installations:

The equipment must only be installed by suitably qualified personnel in accordance with the latest issues of the relevant standards:

The installation of the units must also be in accordance with any local codes that may apply and should only be carried out by a competent electrical engineer who has the necessary training.

The equipment must not be installed with any obstruction to the flanged flameproof joint any closer than permitted as per the NEC/CEC.

For high ambient temperatures the cable entry temperature may exceed +60°C or the cable branching point temperature may exceed 60°C and therefore suitable heat resisting cables and cable glands must be used, with a rated service temperature of at least the values stated below:

For model GNExH1-I:

Max. ambient temperature °C	50	55	60	65	70
req. Cable / Cable Gland rating: °C	60	65	70	75	80

For model GNExH1-IR:

Max. ambient temperature °C	40	45	50	55	60	65	70
req. Cable / Cable Gland rating: °C	60	65	70	75	80	85	90

All Installations:

The cable entries have an M20 x 1.5 – 6H entry thread.

The cable gland entries have an M20 x 1.5 entry thread. Glands to be rated to IP66

When only one cable entry is used the other entries must be closed with plugs to be rated to IP66

The GNExH1 Heat Detector range can be supplied with the following types of adapters:

M20 to ½" NPT  
M20 to ¾" NPT  
M20 to M25

It is important to note that stopping plugs cannot be fitted onto adapters, only directly onto the M20 entries.

Any other adapters used must be suitably rated and IP66 certified adapters.

## 11) Cable Connections

Electrical connections are to be made into the DIN-rail mounted inside the heat detector enclosure.

Electrical connections are to be made into the terminals, using solid wire 0.5-4mm<sup>2</sup> / AWG 20-12 or stranded wire, sizes 0.5-2.5mm<sup>2</sup> / AWG 24-14, and must be suitable for the terminal block type installed.

If fitting 2-off wires to one terminal way the sum of the 2-off wires must be a maximum cross-sectional area of 2.5mm<sup>2</sup>. Strip wires to 8mm. Wires may also be fitted using ferrules.

Terminal screws need to be tightened down with a tightening torque :-  
DIN Rail Terminals: 0.51 Nm / 4.5 Lb-in;

The DIN rail has a 6-way connection.

For full wiring details see wiring diagrams D255-06-251

For EOL and Series device limitations and configurations see Section 12, 15 & 16. Fitting can be requested by E2S at the order stage or added to the correct terminal blocks afterward. All devices must comply with the requirements stipulated in section 12, 15 & 16.

When connecting wires to the terminals great care should be taken to dress the wires so that when the cover is inserted into the chamber the wires do not exert excess pressure on the terminal blocks. This is particularly important when using cables with large cross-sectional areas such as 2.5mm<sup>2</sup>.

## 12) End-of-Line and Series Devices

All GNExH1-IR models can be fitted with series / end-of-line monitoring resistors, monitoring diodes and Zener and also LED options into the terminals of the units with the PCB terminal option.

Min. device values and current limitations must be observed depending on supply voltage and type of components fitted. If a combination of resistors / diodes / zener diodes or LED is used, values for all components must be observed and lowest current limit for either component becomes overall limit.

Current limitation for units fitted with end-of-line or series resistors, diodes or zener diodes must be ensured by using a current limited power supply or fitting a current limiting resistor at the control panel (not provided).

When fitting EOL or series device into the applicable terminal ensure the component is bent to the following specification to ensure the correct creepage and clearance is maintained.

Depending on the wiring option required either of these component lead bending configurations is suitable.

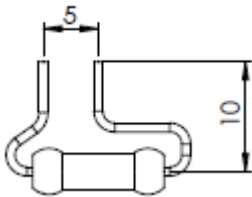

EOL or Series device  
Component Lead Bending

The following table shows limitations for all possible variations:

Type of component fitted	Supply voltage 24Vdc Nom 30Vdc Max via barriers.	
	value	Max. current (mA)
End-of-Line Resistor 5% Max tolerance. Ø3.5 x 9.0mm – 2W Ø2.6 x 6.8mm – 0.5W Min component size	min. 470R / 2W or min. 2k2 / 0.5W	N/A Barrier limit
End-of-Line Diode Type 1N5401 Ø4.8 x 7.2mm Min component size	2W	59.13 customer to limit
Series Resistor 5% Max Tolerance. Ø3.5 x 9.0mm – 2W Ø2.6 x 6.8mm – 0.5W Min component size	min. 470R / 2W or min. 2k2 / 0.5W	N/A Barrier limit
Series Diode Type 1N5401 Ø4.8 x 7.2mm Min component size	2W	59.13 customer to limit
Series Zener Diode Type 1N53xxB Ø3.3 x 8.4mm Min component size	3.3V	230 customer to limit
	4.7V	162 customer to limit
	5.1V	149 customer to limit
	5.6V	136 customer to limit
	6.2V	122 customer to limit
	6.8V	112 customer to limit
	10V	76 customer to limit
	12V	63 customer to limit

Table 2 – EOL Devices

An optional Ex d LED monitoring module is designated after the model no. as either,  
LED Indicator option [u] = L Then the LED will include an LED and power limiting resistor

or,  
LED Indicator option [u] = C Then the LED will include the LED but where the units current must be limited to 20mA.

The optional Ex d LED monitoring module is fitted in the M20 side entry as shown.  
For Wiring See D255-06-001

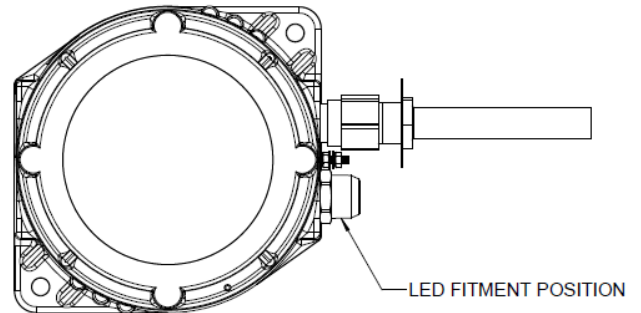

### 13) Heat Detector Option and Testing

The heat detector is available in the following temperature options.

Unit option code [t]	Setting Temperature	Spacings feet (meters)			RTI (1)	Colour Coding (2)
		UL	ULc	FM		
01	140°F / 60°C	50 (15)	50 (15)	25 (8)	Fast	Black
02	160°F / 71°C	25 (8)	25 (8)	25 (8)	Fast	Black
03	190°F / 88°C	50 (15)	50 (15)	25 (8)	Fast	White
04	210°F / 99°C	25 (8)	50 (15)	30 (9)	V- Fast	White
05	225°F / 107°C	25 (8)	50 (15)	30 (9)	V- Fast	White
06	275°F / 135°C	25 (8)	50 (15)	30 (9)	V- Fast	Blue
07	325°F / 163°C	50 (15)	50 (15)	30 (9)	V- Fast	Red
08	360°F / 182°C	25 (8)	50 (15)	30 (9)	V- Fast	Red
09	450°F / 232°C	25 (8)	50 (15)	30 (9)	V- Fast	Green
10	500°F / 260°C	50 (15)	50 (15)	30 (9)	V- Fast	Orange
11	600°F / 316°C	N/A	50 (15)	30 (9)	V- Fast	Orange
12	725°F / 385°C	N/A	50 (15)	30 (9)	V- Fast	Orange

Table 3 – Heat Detector Temperature Codes.

- (1) Response Time Index – Heat Detectors sensitivity and speed see EN54-5
- (2) Colour of detector shell marking band.

## **Functional Test**

The functional test of the heat detector is a GO / No Go Test.

- Disconnect the unit from the system.
- Using a heat gun, or similar heat source, apply heat evenly to the complete heat detector element / shell. The heated air temperature must be above the alarm set point temperature of the unit.
- Using an ohm meter, see that the units internal contacts close when the set temperature is reached. Alternatively connect a 24Vdc bulb and power source in series with the detector to see if bulb light on activation.
- Remove the heat immediately after activation to prevent damage to the detector.
- Allow detector to cool to return to it initial open contact state, if the unit fails to return to the original state or activate replace unit.

Note :- The above test must only be performed if the appropriate steps have been taken to prevent unwarranted system activation/deactivation, or unwarranted discharge of an automatic fire extinguishing system. See note below.

## **HEAT DETECTOR WARNINGS**

For an automatic fire extinguishing system, all releasing devices need to be physically disconnected from the release circuits of the control unit prior to any test. Refer to the automatic fire extinguishing systems maintenance manual for the appropriate steps to be taken to physically disconnect the releasing devices prior to testing the detector. Failure to take the necessary steps could result in an accidental discharge that could cause injury and property damage.

- DO NOT overshoot the set point of the unit by more than 100°F (55°C), this could result in a shift of the set point temperature.
- DO NOT contact the sensing shell with a heating device such as a soldering iron or blowtorch as this will damage the unit and cause a shift in the set point temperature.
- Keep the sensing shell of the unit free from Paint, grease and oil, etc. IF build up occurs, do not attempt to remove the buildup, Replace the unit.
- Detectors mounted in an area of physical abuse or damage must be protected without obstructing the thermal airpaths to the unit.
- Do not install the unit where the shell would be physically damaged by sand, grain, rock, etc.
- Any detector that has been involved in a fire or damaged must be replaced.
- Do not re-install or tighten detector element in junction box.

Note that any of the above could change the factory temperature settings, which may result in property damage and/or personal injury or death. It is possible for a unit to have been abused or damaged and not display any outward indication of the damage. All units should be tested periodically in accordance with National Fire Protection Association Requirements (72e) or the Authority having local jurisdiction.

## **14) Maintenance, Overhaul & Repair**

Maintenance, repair and overhaul of the equipment should only be carried out by suitably qualified personnel in accordance with the current relevant standards:

### **For ATEX / IECEx / UKEx**

EN60079-19/IEC60079-19 Explosive atmospheres - Equipment repair, overhaul and reclamation

EN60079-17/IEC60079-17 Explosive atmospheres - Electrical installations inspection and maintenance

Units must not be opened while an explosive atmosphere is present.

Units must not be opened while an explosive atmosphere is present.

If opening the unit during maintenance operations a clean environment must be maintained and any dust layer removed prior to opening the unit.

Repair of the flameproof threaded joints is not permitted.

Potential electrostatic charging hazard - Clean only with a damp cloth.

### **For NEC / CEC**

UL 60079-19 Explosive atmospheres – Equipment repair, overhaul and reclamation

UL 60079-17 Explosive atmospheres – Electrical installations inspections and maintenance

Potential Electrostatic charging hazard – clean only with a damp cloth.

Units must not be opened while an explosive atmosphere is present.

To avoid a possible ELECTROSTATIC CHARGE the unit must only be cleaned with a damp cloth.

Units must not be opened while an explosive atmosphere is present.

### **Heat Detector for all installations**

As part of the recommended maintenance procedure, perform a visual inspection of the GNExH1 Heat Detector in accordance with NFPA 72 guidelines, ensuring:-

- The heat detector element / shell is free of dents, dings or build up of foreign matter of any kind.
- If the shell is dented or shows signs of any physical damage, replace the unit immediately.
- If a build up of dust has accumulated on the unit, clean the unit with a clean damp cloth.
- If the detector element / shell has been painted, replace the unit. Note that some units are factory coated (set temperature identification band). Do not confuse these with units that were painted by the owners.

## 15) System Design For Installation In Hazardous Areas Using Zener Barriers

ATEX/IECEX & UKEx Installations:

### 15.1 Single Input Barrier

Where the heat detector switch uses a single Zener barrier, as shown in Fig below.

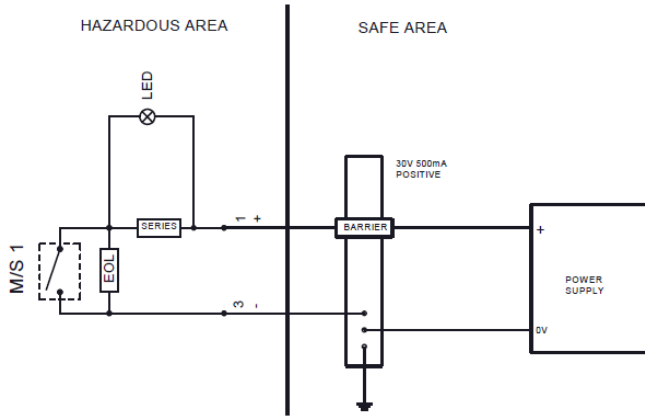

Fig. Single stage heat detector alarm using single barrier.

NEC /CEC Installations:

### 15.2 Single Input Barrier

Where the heat detector switch uses a Zener barrier, as shown in Fig below.

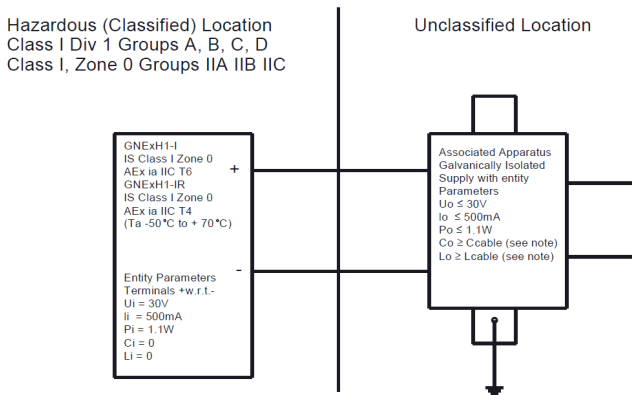

Fig. Single stage call point alarm using single barrier.

1. Associated apparatus output current must be limited by a resistor such that the output voltage current plot is a straight line drawn between open-circuit voltage and short-circuit current.
2. Installed should be in accordance with its manufacturer's control drawing and Article 504 of the National Electrical Code (ANSI/NFPA 70) for Canadian installation in the United States, or Section 18 of the Electrical Code for installations in Canada.
3. Where the cable capacitance and inductance per foot are not known, the following values shall be used:  $C_{cable} = 60 \text{ pF/ft.}$ ,  $L_{cable} = 0.2 \text{ } \mu\text{H/ft.}$

4. When required by the manufacturer's control drawing, the associated apparatus must be connected to a suitable ground electrode per the National Electrical Code (ANSI/NFPA 70), the Canadian Electrical Code, or other local installation codes, as applicable. The resistance of the ground path must be less than 1 ohm.

## 16) Electrical System Design For Installation In Hazardous Areas Using Galvanic Isolators

Galvanic isolators do not require a high integrity earth connection. For small systems where a high integrity earth is not already available, the use of galvanic isolators often reduces the overall installation cost and simplifies design.

ATEX/IECEX & UKEx Installations:

### 16.1 Single Input Barrier

Where the heat detector switch uses a single Zener barrier, as shown in Fig below.

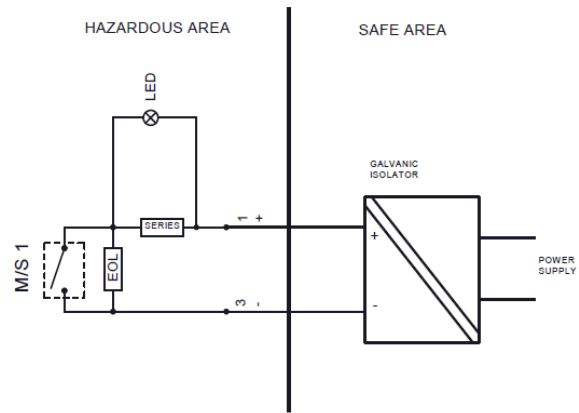

Fig. Single stage heat detector alarm using single galvanic isolator.

NEC /CEC Installations:

### 16.2 Single Input Barrier

Where the heat detector switch uses a single Zener barrier, as shown in Fig below.

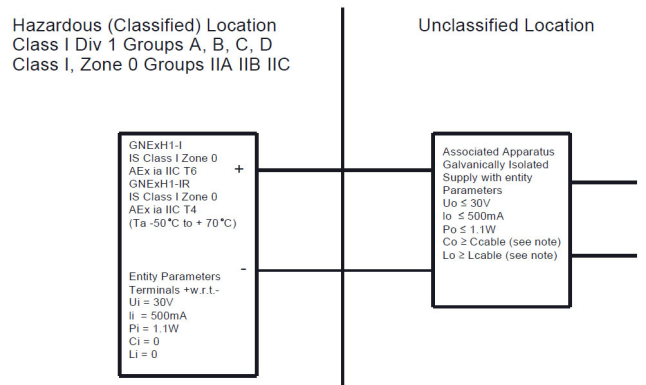

Fig. Single stage call point alarm using single galvanic isolator.



1. Associated apparatus output current must be limited by a resistor such that the output voltage current plot is a straight line drawn between open-circuit voltage and short-circuit current.
2. Installed should be in accordance with its manufacturer's control drawing and Article 504 of the National Electrical Code (ANSI/NFPA 70) for installation in the United States, or Section 18 of the Canadian Electrical Code for installations in Canada.
3. Where the cable capacitance and inductance per foot are not known, the following values shall be used:  $C_{\text{cable}} = 60 \text{ pF/ft.}$ ,  $L_{\text{cable}} = 0.2 \text{ }\mu\text{H/ft.}$

**HEAT DETECTOR DEVICES**

**SHEET 1**

PRODUCTS: D1xH1 ; STExH1	<b>Diagram</b>	<b>Sheet</b>
	Standard Switch Wiring Configurations	1
	LED Indicator Wiring Configurations, Use for -IR units only)	2

**NOTE :**  
**ALL Ex ia CIRCUITS REQUIRE THE USE OF ZENER BARRIERS OR GALVANIC ISOLATORS, SEE PRODUCT MANUAL**

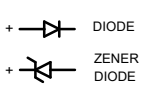

Module Device Codes		
	EOL	Series
Resistor	ExxxR	SxxxR
Diode	ED1	SD1
Zener Diode	ExxxZ	SxxxZ
LED	N/A	L or C

ISSUE	MOD No.	REASON - INITIAL - DATE
1		INTRODUCTION RNP 31-05-2024

HEAT DETECTOR	CONFIG. A1-1	HEAT DETECTOR WITH EOL DEVICE	CONFIG. A1-2	HEAT DETECTOR WITH SERIES DEVICES	CONFIG. A1-3	HEAT DETECTOR WITH EOL & SERIES DEVICES	CONFIG. A1-4	HEAT DETECTOR WITH EOL & ALT. SERIES DEVICES	CONFIG. A1-5
---------------	--------------	-------------------------------	--------------	-----------------------------------	--------------	---	--------------	--	--------------

PRODUCT VERSION [v]	[I]	Ex ia	PRODUCT VERSION [v]	[R]	Ex ia (-IR)	PRODUCT VERSION [v]	[R]	Ex ia (-IR)	PRODUCT VERSION [v]	[R]	Ex ia (-IR)
PRODUCT OPTION [o]	[1]	Default	PRODUCT OPTION [o]	[1]	Default	PRODUCT OPTION [o]	[1]	Default	PRODUCT OPTION [o]	[W]	Alt. EOL Pos'n.
LED INDICATOR [u]	[N]	N/A	LED INDICATOR [u]	[N]	NO LED	LED INDICATOR [u]	[N]	NO LED	LED INDICATOR [u]	[N]	NO LED
			SERIES MODULE [e]	[Exxxx]	EOL	SERIES MODULE [s]	[Sxxxx]	Series	MODULE [e][s]	[Exxxx]	EOL + Series

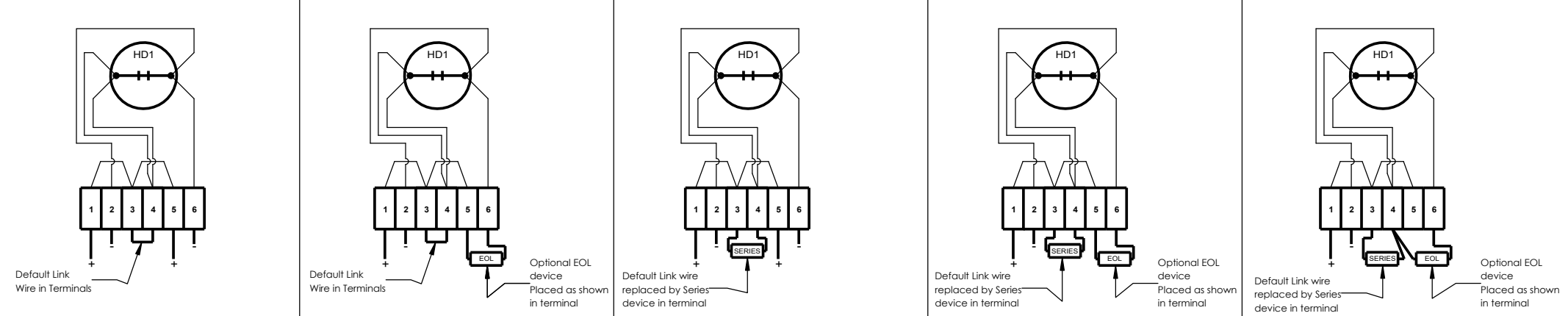
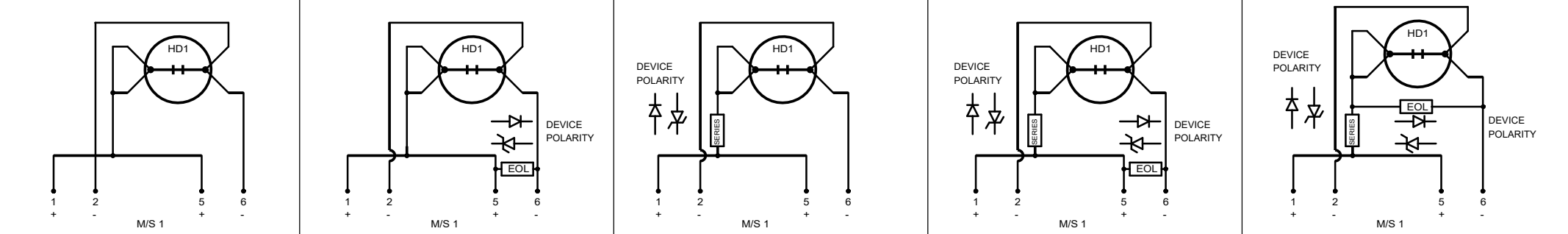

**Circuit shown in Unoperated condition**

**Unoperated condition (Heat Detector in Standby Condition)**  
 Terminals (+1,-2) & (+5,-6) open

**Operated condition (Heat Detector in operated condition)**  
 Terminals (+1,-2) & (+5,-6) closed

DRAWING TO BS8888:2000 GEOMETRIC TOLERANCES TO ISO1101:1983 LINEAR DIMENSIONAL TOLS ANGULAR DIMENSIONAL TOLS	DRAWN	DATE	SURFACE FINISH	WEIGHT (Kg)	THIS DRAWING AND ANY INFORMATION OR DESCRIPTIVE MATTER THEREIN IS COMMUNICATED IN CONFIDENCE AND IS THE COPYRIGHT PROPERTY OF EUROPEAN SAFETY SYSTEMS LTD. NEITHER THE WHOLE OR ANY EXTRACT MAY BE DISCLOSED, LOANED, COPIED OR USED FOR MANUFACTURING OR TENDERING PURPOSES WITHOUT THEIR WRITTEN CONSENT.	 EUROPEAN SAFETY SYSTEMS LTD IMPRESS HOUSE MANSSELL ROAD ACTON LONDON W3 7QH WWW.E2S.COM	ALL DIMENSIONS IN MM IF IN DOUBT, ASK - DO NOT SCALE			
	CHECKED	DATE					TITLE <b>GNExH1-I &amp; -IR ; D2xH1-I &amp; -IR Ex ia HEAT DETECTOR WIRING / CIRCUIT OPERATION DIAGRAM</b>			
	STANDARDS <b>GNExH1-I ; GNExH1-IR ;                  D2xH1-I ; D2xH1-IR</b>	APPROVED	DATE	ALTERNATIVE MATERIAL			EUROPEAN SAFETY SYSTEMS LTD. AS PER LATEST DATE OF ISSUE SHOWN ABOVE	SCALE	SHEET	DRAWING NUMBER
	R.N.POTTS	31-05-2024					NTS	1 OF 2	<b>D255-06-251</b>	

# HEAT DETECTOR WITH LED DEVICES

# SHEET 2

**NOTE :**  
**ALL Ex ia CIRCUITS REQUIRE THE USE OF ZENER BARRIERS OR GALVANIC ISOLATORS, SEE PRODUCT MANUAL**

Notes:

- LED option 'L': LED contains the 1.5K Ohm series current-limiting resistor RL1.  
 LED option 'C': LED does not contain a current-limiting resistor. System current must be <20mA.  
 All schematic diagrams below show option 'L' LED - remove RL1 for 'C' LED option.

### Module Device Codes

	EOL	Series
Resistor	ExxxR	SxxxR
Diode	ED1	SD1
Zener Diode	ExxxZ	SxxxZ
LED	N/A	L or C

ISSUE	MOD No.	REASON - INITIAL - DATE
1		INTRODUCTION RNP 31-05-2024

HEAT DETECTOR WITH LED ONLY	CONFIG. A2-1	HEAT DETECTOR WITH LED & EOL DEVICE	CONFIG. A2-2	HEAT DETECTOR WITH LED EOL & SERIES DEVICES	CONFIG. A2-3	HEAT DETECTOR WITH LED, EOL & ALT. SERIES DEVICE	CONFIG. A2-4
-----------------------------	--------------	-------------------------------------	--------------	---	--------------	--	--------------

PRODUCT VERSION [v] [R] PRODUCT OPTION [o] [1] LED INDICATOR [u] [L]	Ex ia (-IR only) Default LED with RL1	PRODUCT VERSION [v] [R] PRODUCT OPTION [o] [1] LED INDICATOR [u] [L] MODULE [E] [Exxxx]	Ex ia (-IR Only) Default LED with RL1 EOL Device	PRODUCT VERSION [v] [R] PRODUCT OPTION [o] [1] LED INDICATOR [u] [L] MODULES [e] [s] [Exxxx] [Sxxxx]	Ex ia (-IR only) Default LED with RL1 EOL + Series	PRODUCT VERSION [v] [R] PRODUCT OPTION [o] [W] LED INDICATOR [u] [L] MODULE [e] [s] [Exxxx] [Sxxxx]	Ex ia (-IR only) Alt. EOL Pos'n. LED with RL1 EOL + Series
--	---	--	---	---	---	--	---

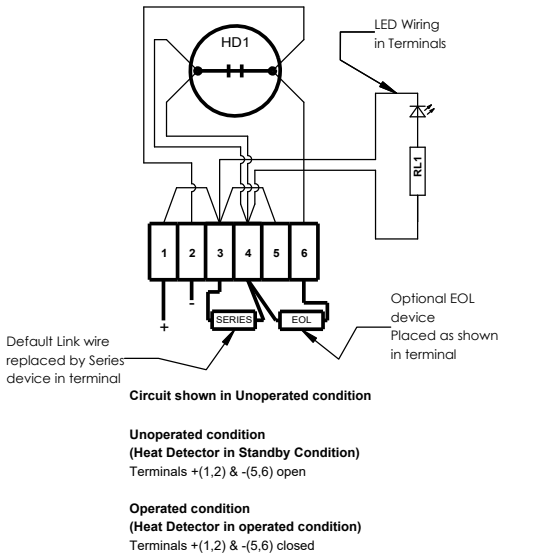
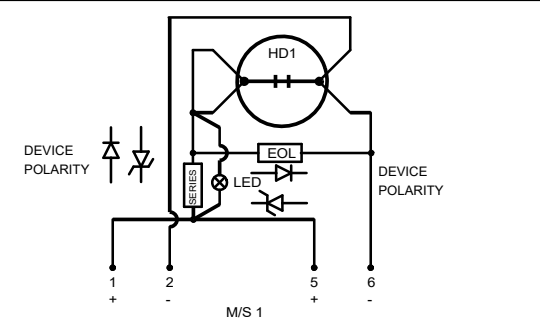
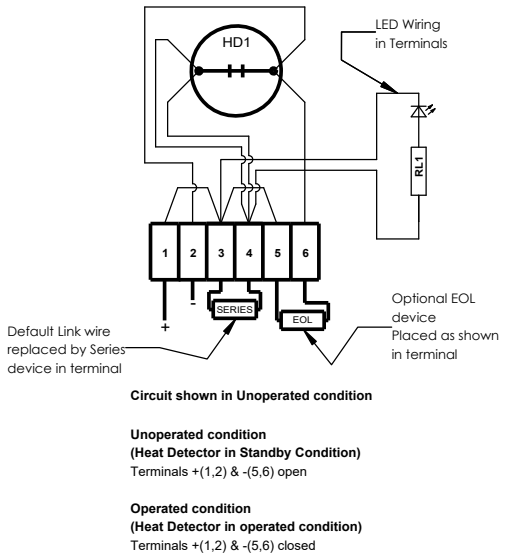
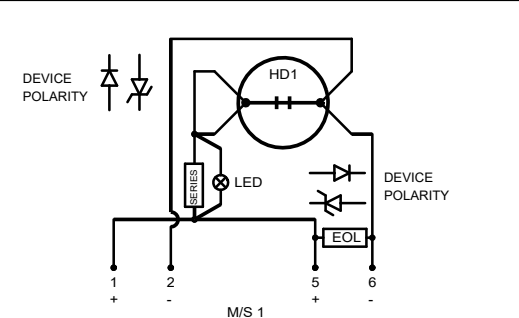
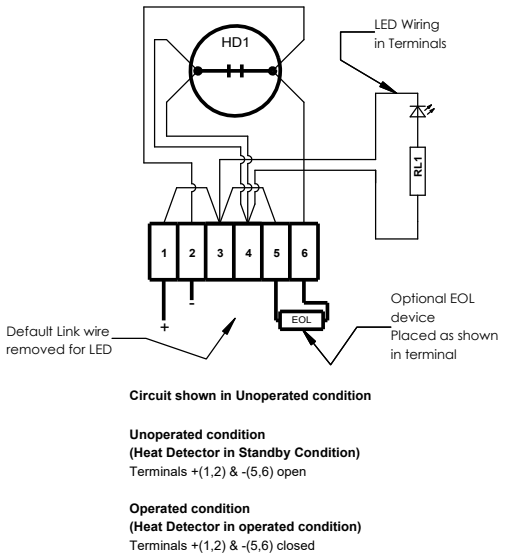
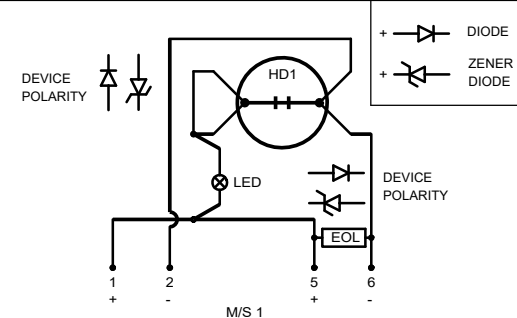
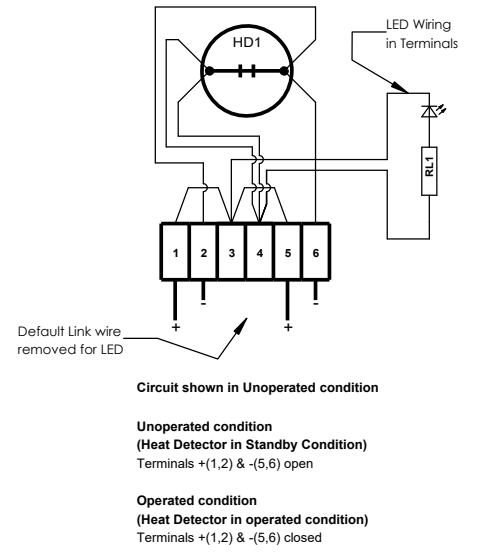
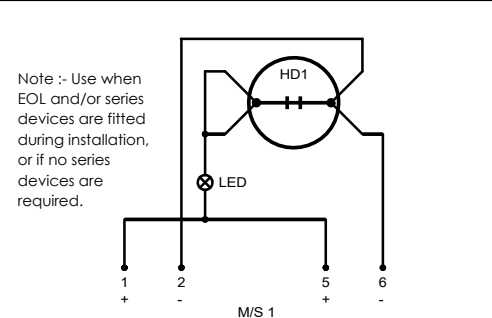

DRAWING TO BS8888:2000  
 GEOMETRIC TOLERANCES TO ISO1101:1983  
 LINEAR DIMENSIONAL TOLS  
 ANGULAR DIMENSIONAL TOLS

STANDARDS  
 GNExH1-IR ;  
 D2xH1-IR

DRAWN R.N.POTTS DATE 31-05-2024

CHECKED B.ISARD DATE 31-05-2024

APPROVED R.N.POTTS DATE 31-05-2024

SURFACE FINISH WEIGHT (Kg)

MATERIAL

ALTERNATIVE MATERIAL

THIS DRAWING AND ANY INFORMATION OR DESCRIPTIVE MATTER THEREIN IS COMMUNICATED IN CONFIDENCE AND IS THE COPYRIGHT PROPERTY OF EUROPEAN SAFETY SYSTEMS LTD. NEITHER THE WHOLE OR ANY EXTRACT MAY BE DISCLOSED, LOANED, COPIED OR USED FOR MANUFACTURING OR TENDERING PURPOSES WITHOUT THEIR WRITTEN CONSENT.

EUROPEAN SAFETY SYSTEMS LTD.  
 AS PER LATEST DATE OF ISSUE SHOWN ABOVE

**e2s** warning signals  
 EUROPEAN SAFETY SYSTEMS LTD  
 IMPRESS HOUSE  
 MANSFELD ROAD  
 ACTON  
 LONDON W3 7QH  
 WWW.E2S.COM

ALL DIMENSIONS IN MM  
 IF IN DOUBT, ASK -  
 DO NOT SCALE

**A3**

TITLE  
**GNExH1-I & -IR ; D2xH1-I & -IR Ex ia HEAT DETECTOR WIRING / CIRCUIT OPERATION DIAGRAM**

SCALE NTS SHEET 2 OF 2 DRAWING NUMBER **D255-06-251**

# EU Declaration of Conformity



Manufacturer: European Safety Systems Ltd.  
Impress House, Mansell Road, Acton  
London, W3 7QH  
United Kingdom

Authorised Representative: E2S Warnsignaltechnik UG  
Charlottenstrasse 45-51  
72764 Reutlingen  
Germany

Equipment Type: GNExH1-I, GNExH1-IR

---

## Directive 2014/34/EU: Equipment and Protective Systems for use in Potentially Explosive Atmospheres (ATEX)

Notified Body for EU type Examination (Module B):	UL International Demko A/S Notified Body No.: 0539 Borupvang 5A, 2750 Ballerup, Denmark
EU-type Examination Certificate (Module B):	DEMKO 15 ATEX 1448X
Notified Body for Quality Assurance Notification / Conformity to EU-type based on quality assurance of the production process (Module D):	Sira Certification Service Notified Body No.: 2813 Unit 6, Hawarden Industrial Park, Hawarden, Deeside, CH5 3US, UK
Quality Assurance Notification (Module D):	SIRA 05 ATEX M342
Provisions fulfilled by the equipment:	II 1G Ex ia IIC T6...T4 Ga II 2D Ex tb IIIC T75°C Db
Standards applied:	EN IEC 60079-0:2018 EN 60079-11:2012 EN60079-31:2014

## Directive 2014/30/EU: Electromagnetic Compatibility Directive (EMC)

Standards applied:	EN 61000-6-1:2007 EN 61000-6-2:2005 EN 61000-6-3:2007 / A1:2011 / AC: 2012 EN 61000-6-4:2007 / A1: 2011
--------------------	--

## Directive 2014/35/EU: Low Voltage Directive (LVD)

Standards applied:	EN 60947-1:2007 + A2:2014
--------------------	---------------------------

## Directive 2011/65/EU: Restriction of the use of certain hazardous substances in electrical and electronic equipment (RoHS)

The product and all the components contained within it are in accordance with the restriction of the use of hazardous substances in electrical and electronic equipment, including amendment by Directive 2015/863/EU.

## Regulation (EC) 1907/2006: Registration, Evaluation, Authorisation and Restriction of Chemicals (REACH)

The product and all the components contained within it are free from substances of very high concern.

## Other Standards and Regulations

EN 60529:1992+A2:2013 - Degrees of protection provided by enclosures (IP code) – enclosure rated IP66/7

---

On behalf of European Safety Systems Ltd., I declare that, on the date the equipment accompanied by this declaration is placed on the market, the equipment conforms with all technical and regulatory requirements of the above listed directives, regulations and standards.

This Declaration is issued under the sole responsibility of the manufacturer.

A blue ink signature of Desmond Gayler.

Desmond Gayler  
Quality Assurance Manager

Document No.: DC-127\_Issue\_A  
Date and Place of Issue: London, 07/06/2024

Manufacturer: European Safety Systems Ltd.  
Impress House, Mansell Road, Acton  
London, W3 7QH  
United Kingdom

Equipment Type: GNExH1-I, GNExH1-IR

---

Directive UKSI 2016:1107 (as amended by UKSI 2019:696) – Schedule 3A, Part 1 : Product or Protective System Intended for use in Potentially Explosive Atmospheres (UKCA)

Notified Body for UK type Examination (Module B):	UL International (UK) Ltd Notified Body No.: 0843 Unit 1-3 Horizon Kingsland Business Park, Wade Road, Basingstoke, Hampshire RG24 8AH UK
UK-type Examination Certificate (Module B):	UL21UKEX2130X
Notified Body for Quality Assurance Notification / Conformity to EU-type based on quality assurance of the production process (Module D):	Sira Certification Service Notified Body No.: 0518 Rake Lane, Eccleston, Chester CH4 9JN, UK
Quality Assurance Notification (Module D):	CSAE 22UKQAN0046
Provisions fulfilled by the equipment:	II 1G Ex ia IIC T6...T4 Ga II 2D Ex tb IIIC T75°C Db
Standards applied:	EN IEC 60079-0:2018 EN 60079-11:2012 EN60079-31:2014

Directive 2014/30/EU: Electromagnetic Compatibility Directive (EMC)

Standards applied:	EN 61000-6-1:2007 EN 61000-6-2:2005 EN 61000-6-3:2007 / A1:2011 / AC: 2012 EN 61000-6-4:2007 / A1: 2011
--------------------	--

Directive 2014/35/EU: Low Voltage Directive (LVD)

Standards applied:	EN 60947-1:2007 + A2:2014
--------------------	---------------------------

Directive 2011/65/EU: Restriction of the use of certain hazardous substances in electrical and electronic equipment (RoHS)

The product and all the components contained within it are in accordance with the restriction of the use of hazardous substances in electrical and electronic equipment, including amendment by Directive 2015/863/EU.

Regulation (EC) 1907/2006: Registration, Evaluation, Authorisation and Restriction of Chemicals (REACH)

The product and all the components contained within it are free from substances of very high concern.

Other Standards and Regulations

EN 60529:1992+A2:2013 - Degrees of protection provided by enclosures (IP code) – enclosure rated IP66/7

---

On behalf of European Safety Systems Ltd., I declare that, on the date the equipment accompanied by this declaration is placed on the market, the equipment conforms with all technical and regulatory requirements of the above listed directives, regulations and standards.

This Declaration is issued under the sole responsibility of the manufacturer.



Desmond Gayler  
Quality Assurance Manager

Document No.: DC-135\_Issue\_A  
Date and Place of Issue: London, 07/06/2024